

# **Agenda: Physical Access in Health Care**

ADA General Concepts and Applicability

Parking, Passenger Loading Zones and Drive-thru Medical Testing

Building and Office Accessibility

Accessible Exam Rooms and Waiting Areas

Accessible Medical Diagnostic Equipment

# Learning Objectives:

- Understand how the ADA applies to health care facilities.
- Identify areas of health care facilities in which physical accessibility is required.
- Learn how to address common barriers to access in health care facilities.

# Accessibility in Healthcare

- Accessibility of doctors' offices, clinics, and other health care providers is essential in providing medical care to people with disabilities.
- Due to barriers, individuals with disabilities are less likely to get routine preventative medical care than people without disabilities.
- Accessibility is not only legally required; it is important medically so that minor problems can be detected and treated before turning into major and possibly life-threatening problems.

# ADA Overview and Requirements I

- The Americans with Disabilities Act of 1990 (ADA) is a federal civil rights law that prohibits discrimination against individuals with disabilities in everyday activities, including medical services.
  - Disability – A physical or mental impairment that substantially limits one or more major life activity
- The ADA ensures access to the built environment for people with disabilities.
  - Enforced by the Department of Justice
  - Uses the [2010 Standards for Accessible Design](#).

# ADA Overview and Requirements II

- Design standards developed and updated by the [US Access Board](#).
  - Apply to places of public accommodation, commercial facilities, and state and local governments.
  - Became enforceable in 2012 – for all new construction, alterations, program accessibility, and barrier removal.

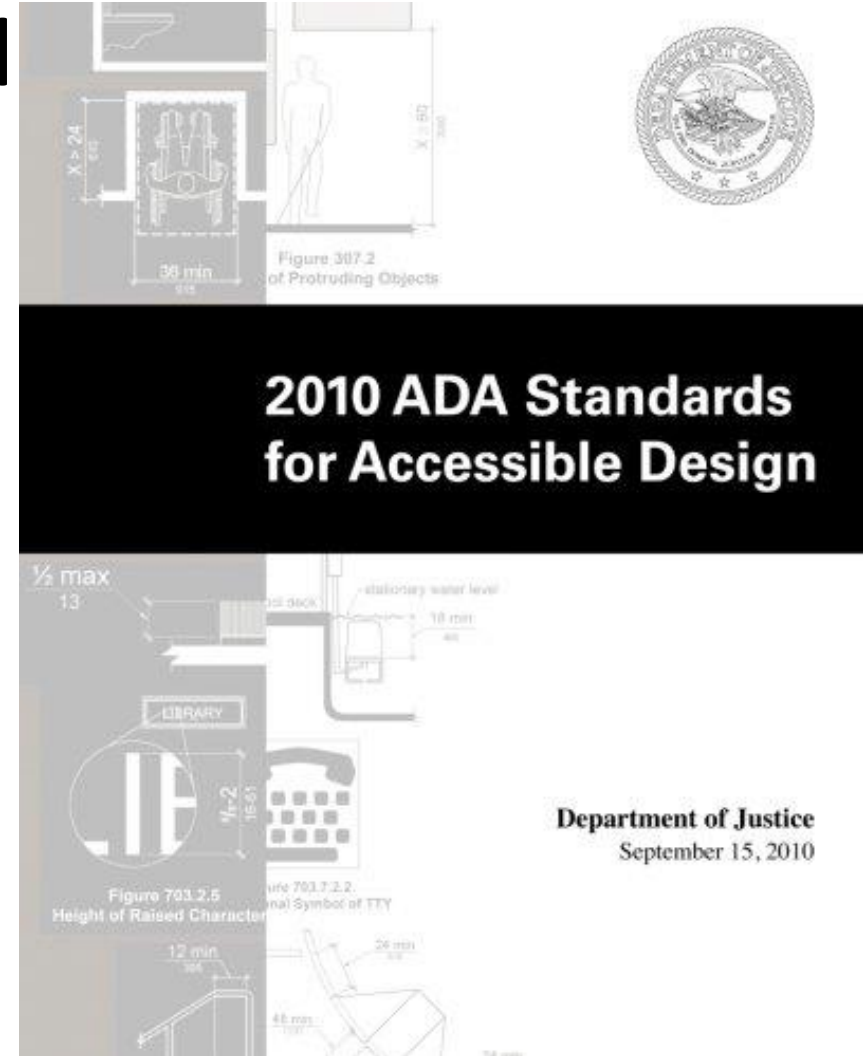

# ADA Overview and Requirements III

- Title II (State and Local Government)
  - Public Hospitals, Clinics, Medical Offices
- Title III (Public Accommodations)
  - Private Hospitals, Clinics, Medical Offices
- Both must provide:
  - Full and equal access to healthcare services and facilities
  - Reasonable modifications to policies practices and procedures

# ADA Overview and Requirements IV

- Existing Facility Accessibility Requirements
  - Title II
    - Program as a whole must be accessible.
    - May mean removing architectural barriers or adopting alternative measures.
  - Title III
    - Readily achievable barrier removal.
    - If barriers cannot be removed, must make services available through alternative methods.

# Parking Requirements

- Parking facility includes parking lots and parking structures
- The number of parking spaces required to be accessible is to be calculated separately for each parking facility; not based on the total number of parking spaces provided in all the parking facilities provided on the site.





# Parking Requirements – Scoping I

[Table 208.2](#) Parking Spaces

Total Number of Parking Spaces Provided in Parking Facility	Minimum Number of Required Accessible Parking Spaces
1 to 25	1
26 to 50	2
51 to 75	3
76 to 100	4
101 to 150	5
151 to 200	6
201 to 300	7
301 to 400	8
401 to 500	9
501 to 1000	2 percent of total
1001 and over	20, plus 1 for each 100, or fraction thereof, over 1000

# Parking Requirements – Scoping II

- **Hospital Outpatient Facilities.** Ten percent of patient and visitor parking spaces provided to serve hospital outpatient facilities must be accessible.
  - Intended to cover facilities or units that are **located in hospitals** and that provide regular and continuing medical treatment **without an overnight stay**.
  - Doctors' offices, independent clinics, or other facilities not located in hospitals are **not considered hospital outpatient facilities**.

# Parking Requirements – Scoping III

- **Rehabilitation Facilities and Outpatient Physical Therapy Facilities.** Twenty percent of patient and visitor parking spaces provided to serve rehabilitation facilities specializing in treating conditions that **affect mobility** and outpatient physical therapy facilities must be accessible.
- Conditions that affect mobility:
  - Conditions requiring the use of a mobility aid;
  - Arthritic, neurological, or orthopedic conditions;
  - Respiratory diseases and other conditions; and
  - Cardiac conditions that impose significant functional limitations.

# Parking Requirements – Scoping IV

- **Van Parking Spaces.** For every six or fraction of six parking spaces required to be accessible, at least one shall be an accessible van parking space.



# Parking Requirements - Location

- Accessible spaces for a particular building must be located on the **shortest accessible route** from parking to an accessible entrance.
- Where parking serves more than one accessible entrance, accessible parking spaces shall be **dispersed**.
- In parking facilities that do not serve a particular building, accessible spaces must be located on the shortest accessible route to an **accessible pedestrian entrance** of the parking facility.

# Parking Requirements – Design I

- Car Parking Spaces
  - 8' wide minimum
  - 5' wide access aisle



# Parking Requirements – Design II

- Van Parking Spaces
  - 11' wide minimum
  - 5' wide access aisle, **OR**
  - 8' wide minimum
  - 8' wide access aisle
- Parking spaces for vans and access aisles and vehicular routes serving them shall provide a **vertical clearance** of 98 inches minimum.

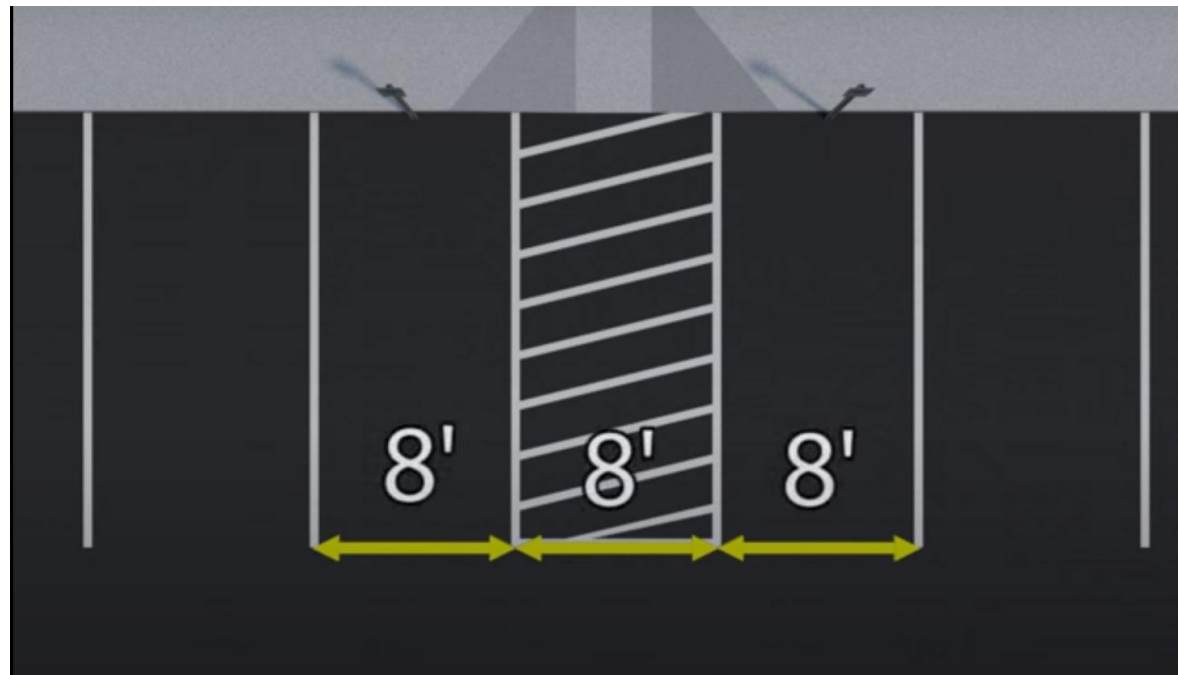
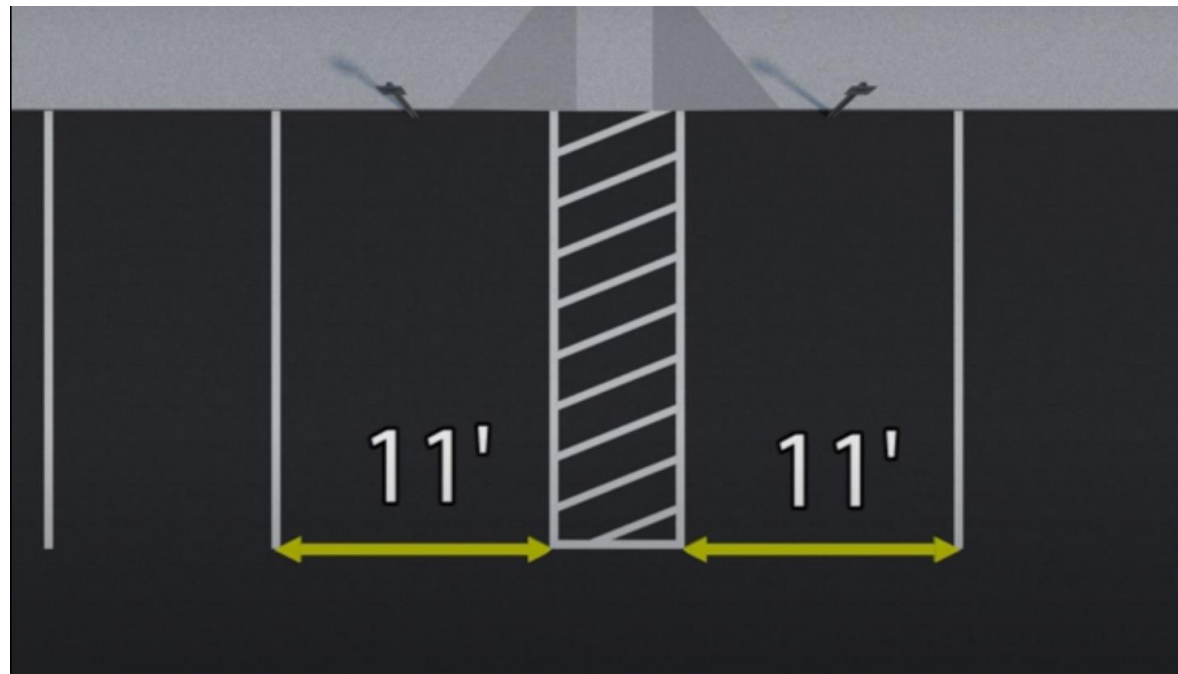

# Parking Requirements – Design III

- Access Aisle
  - Must adjoin an accessible route.
  - Two parking spaces are permitted to share an access aisle.
  - Must extend the full length of the parking space.
  - Must be marked to discourage parking in them.
  - Must not overlap the vehicular way.
  - Van access aisles be on either side of the parking space, except with angled spaces.



# Parking Requirements – Design IV

- Parking space and access aisle surfaces must be stable, firm, and slip resistant.
- Access aisles must be at the same level as parking spaces they serve.
- Changes in level greater than 1:48 are not permitted.
- Built-up curb ramps cannot protrude into access aisles.





## Parking Requirements – Design V

- Parking spaces must be identified with the International Symbol of Accessibility.
- Signs identifying van parking spaces shall contain the designation "van accessible."
- Signs shall be 5 feet minimum above the finish floor or ground surface measured to the bottom of the sign.
- Signs can be installed on posts, suspended from ceilings, or fixed to walls.

# Passenger Loading Requirements – Scoping I

Where provided, at least one accessible passenger loading zone must be provided in every continuous 100 linear feet of loading zone space, or fraction thereof.

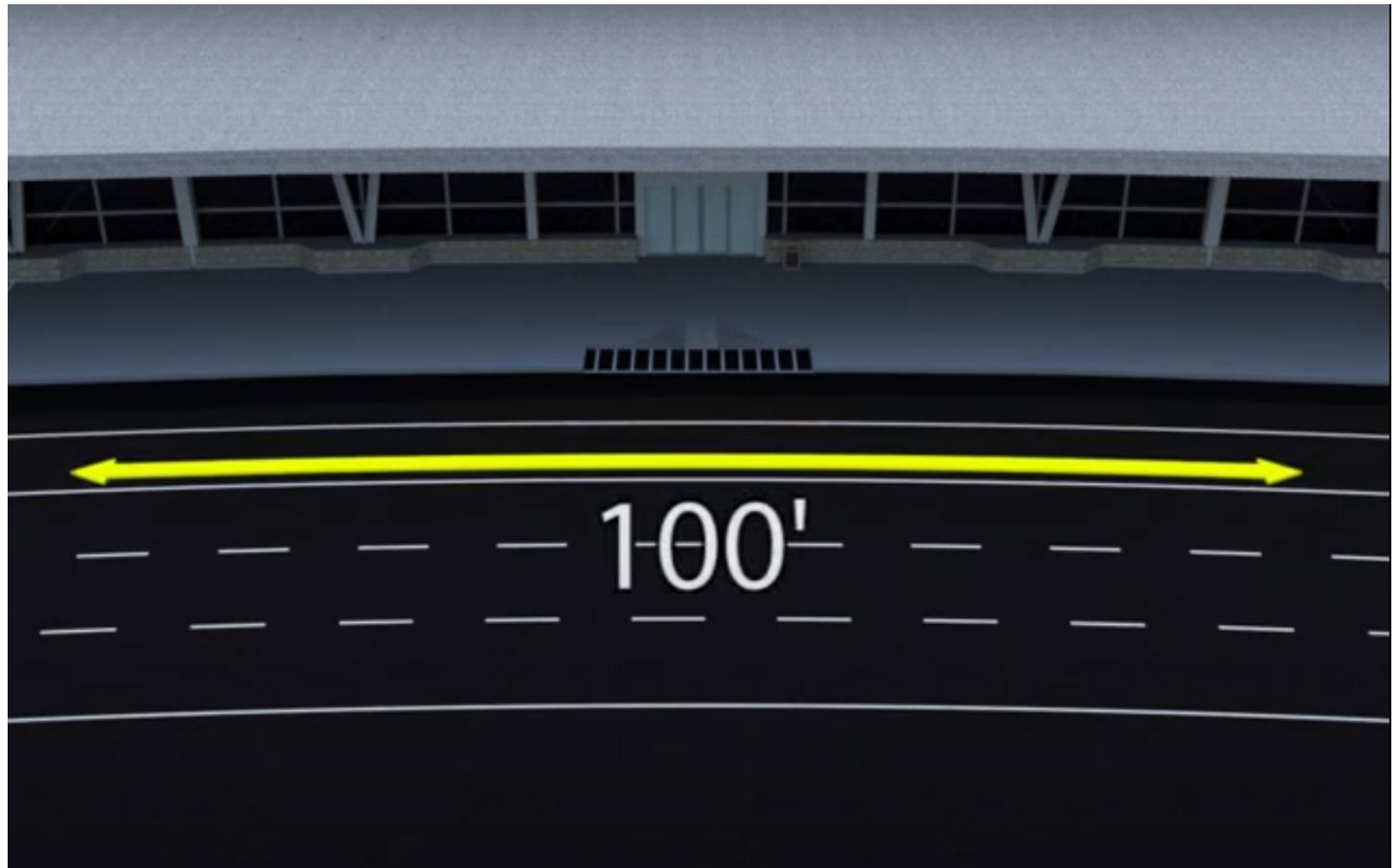

# Passenger Loading Requirements – Scoping II

- **Medical Care and Long-Term Care Facilities.** At least one accessible passenger loading zone shall be provided at an accessible entrance to licensed medical care and licensed long-term care facilities where the period of stay exceeds twenty-four hours.
- **Valet Parking.** Parking facilities that provide valet parking services shall provide at least one accessible passenger loading zone.
- **Mechanical Access Parking Garages.** Mechanical access parking garages shall provide at least one accessible passenger loading zone at vehicle drop-off and vehicle pick-up areas.

# Passenger Loading Requirements – Design I

- **Vehicle Pull-Up Space.** Passenger loading zones shall provide a vehicular pull-up space 8 feet wide minimum and 20 feet long minimum.

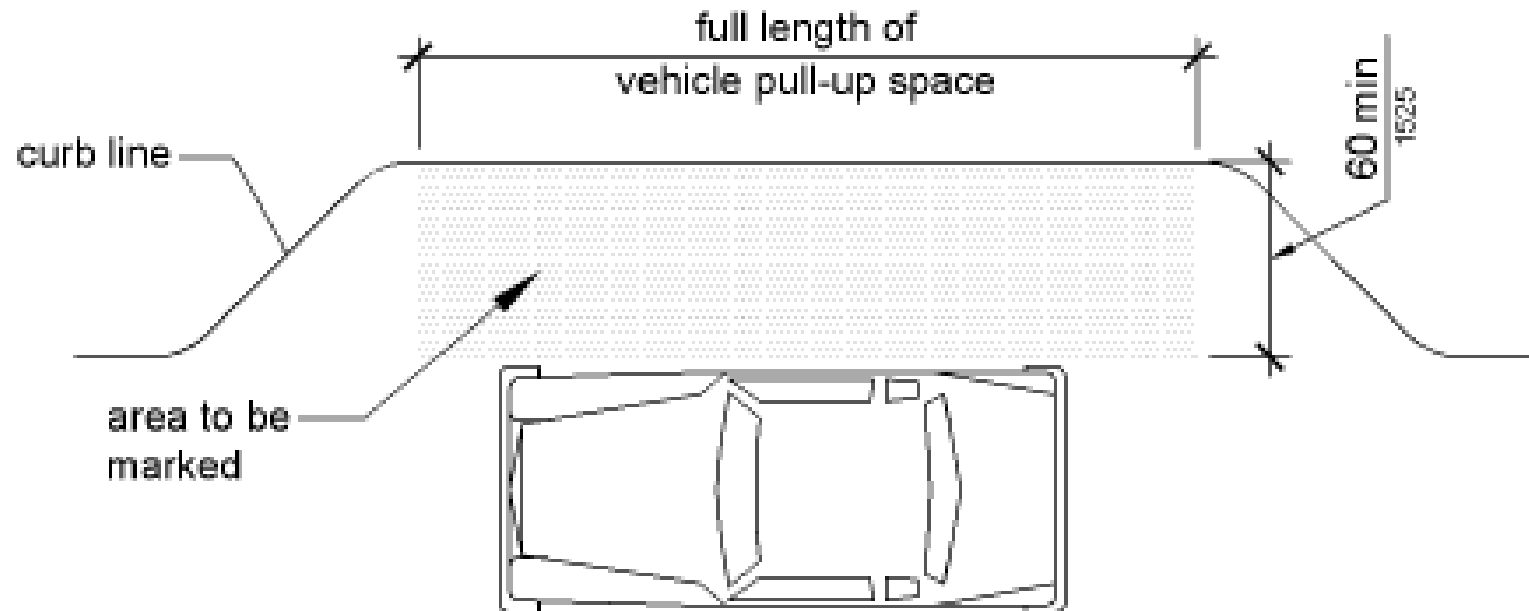

# Passenger Loading Requirements – Design II

- **Access Aisle.** Passenger loading zones shall provide access aisles adjacent to the vehicle pull-up space.
  - Access aisles shall adjoin an accessible route and shall not overlap the vehicular way.
  - Access aisles serving vehicle pull-up spaces shall be at least 5 feet wide.
  - Access aisles shall extend the full length of the vehicle pull-up spaces they serve.
  - Access aisles shall be marked to discourage parking in them.

# Passenger Loading Requirements – Design III

- Vehicle pull-up spaces and access aisles serving them must be stable, firm, and slip resistant.
- Access aisles must be at the same level as the vehicle pull-up space they serve.
- Changes in level greater than 1:48 are not permitted.
- Vehicle pull-up spaces, access aisles, and vehicular routes must have a vertical clearance of at least 114 inches.

# Accessible Routes - Scoping

- Accessible Routes permit people with mobility disabilities to travel between site arrival points to accessible entrances.
- At least one accessible route shall be provided within the site from accessible parking spaces and accessible passenger loading zones; public streets and sidewalks; and public transportation stops to the accessible building or facility entrance they serve.





# Accessible Routes - Location

- The accessible route must be in the same area as the general circulation path.

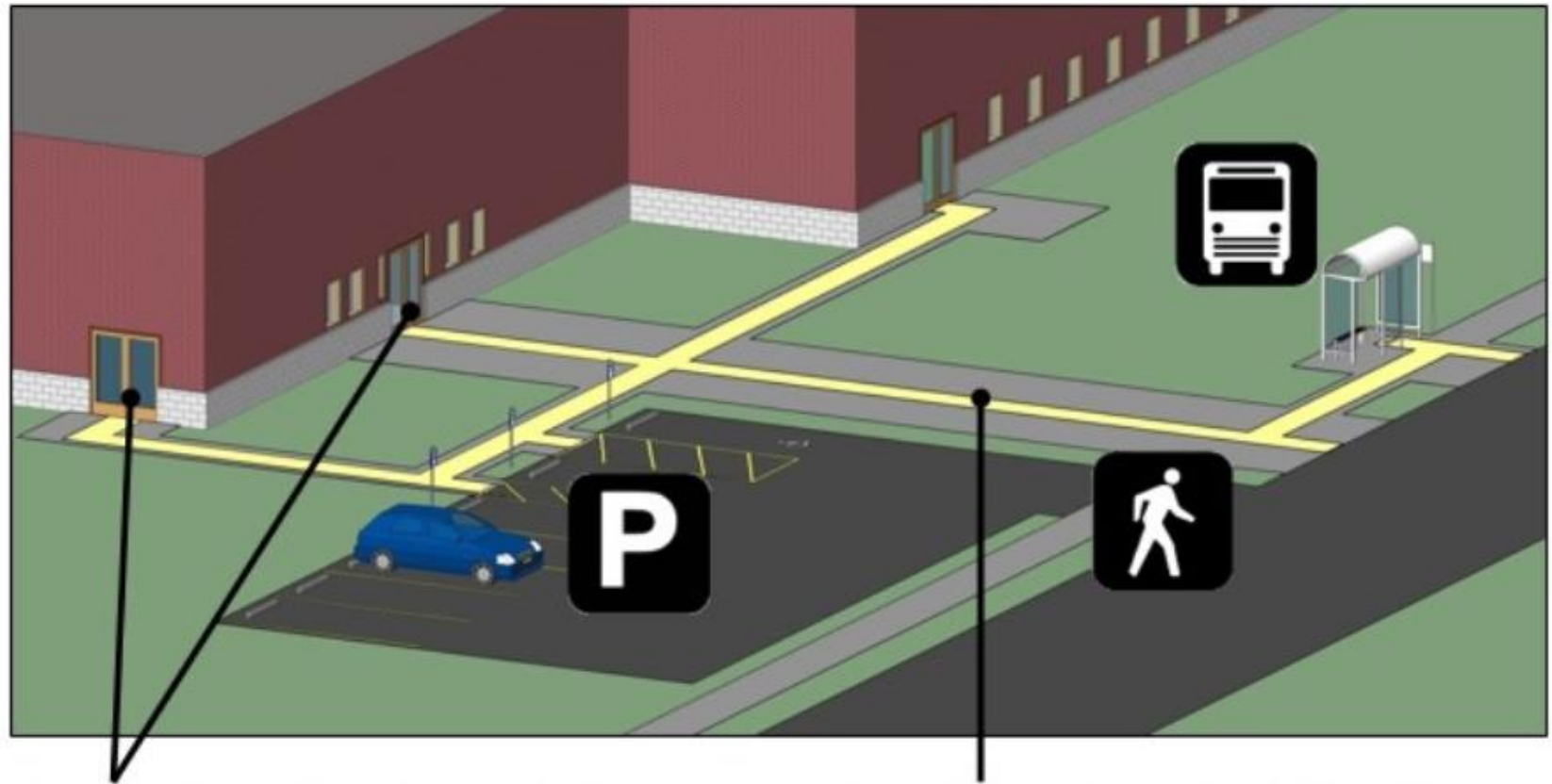

*An accessible route must connect site arrival points to each accessible entrance they serve.*

*Accessible routes must coincide with, or be in the same vicinity as, general circulation paths (§206.3).*

# Accessible Routes – Design I

- Accessible route floor or ground surfaces must be firm, stable and slip resistant.



## Accessible Routes – Design II

- Walking surfaces should have a 5% maximum running slope
- Ramps should have a 5-8.3% maximum running slope
- Cross slopes should never exceed 2%.

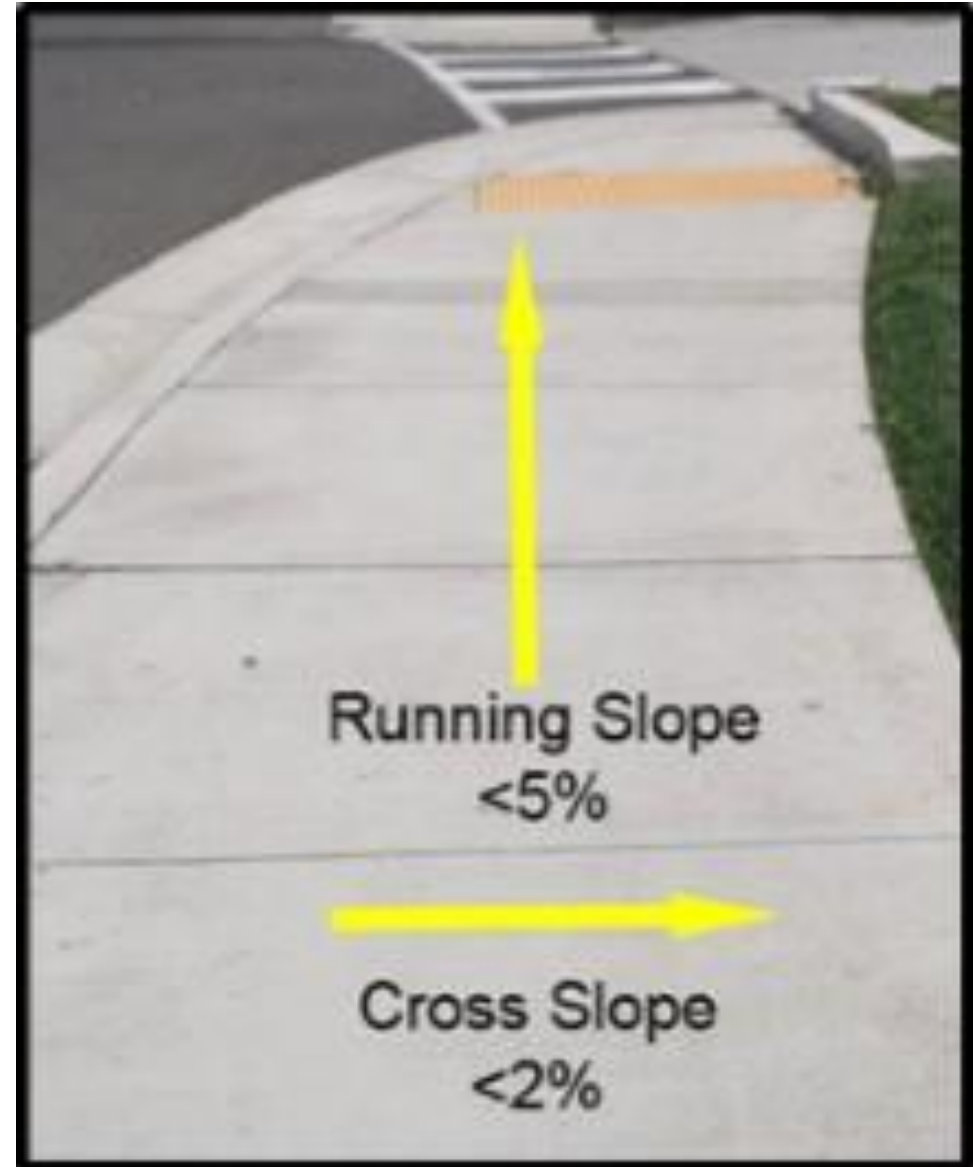

# Accessible Routes – Design III

- Walking surfaces should be free from gaps greater than  $\frac{1}{2}$  inch
- Vertical changes in level cannot be greater than  $\frac{1}{4}$  inch.
- Vertical changes in level up to  $\frac{1}{2}$  inch should be beveled at 1:2.

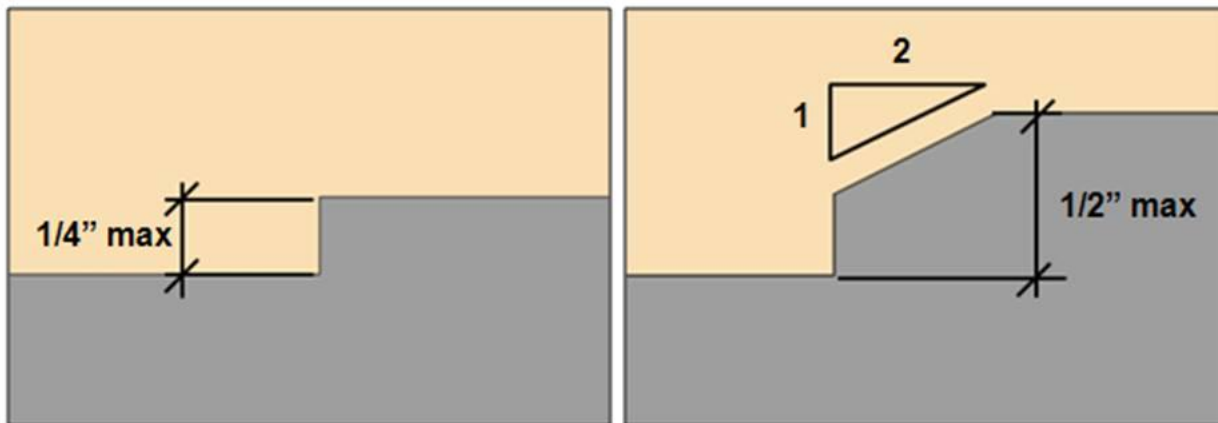
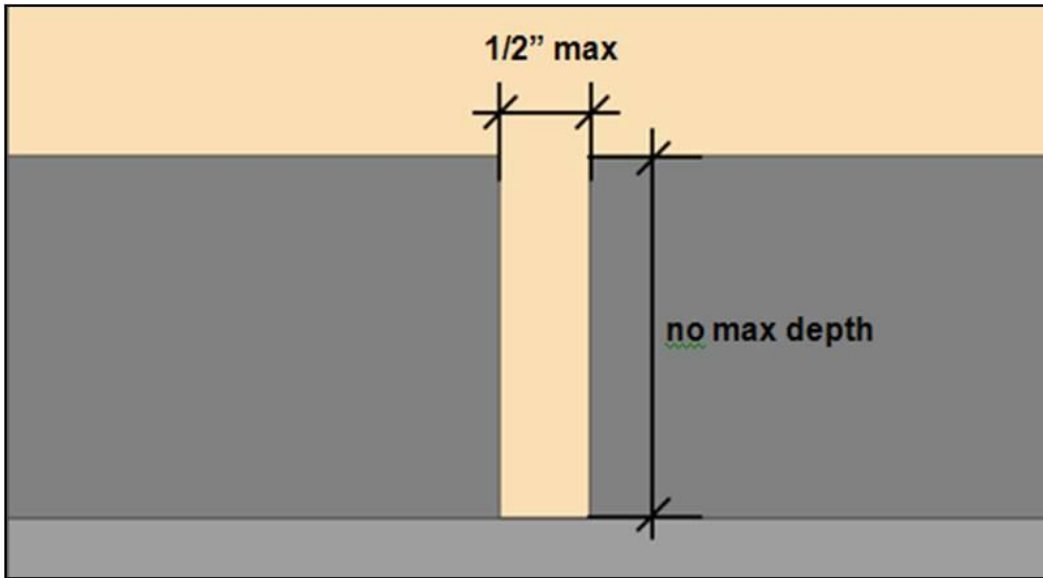

# Accessible Routes – Design IV

- Pathways should be 36 inches wide except at doors and for short distances, when it can be narrower (32 inches).

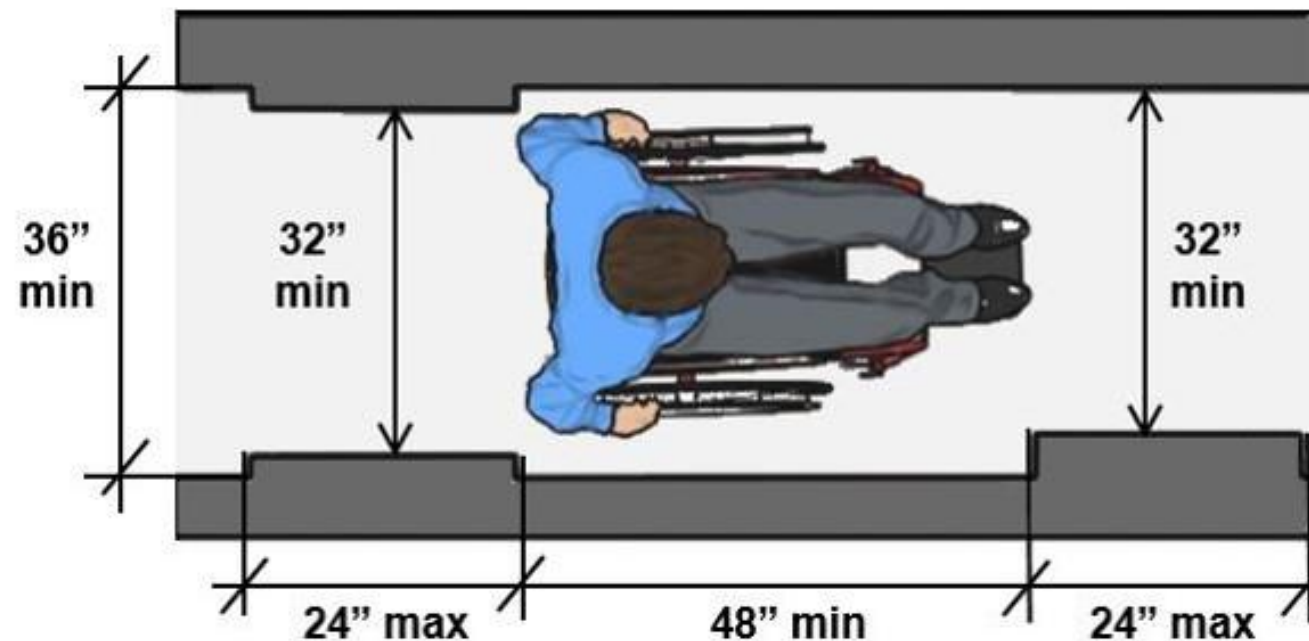

# Accessible Routes – Design V

- Ramps which rise more than 6 inches will need to have both handrails and edge protection.
- Ramps must also have level landings at the top and bottom of each segment and where the ramp changes direction.

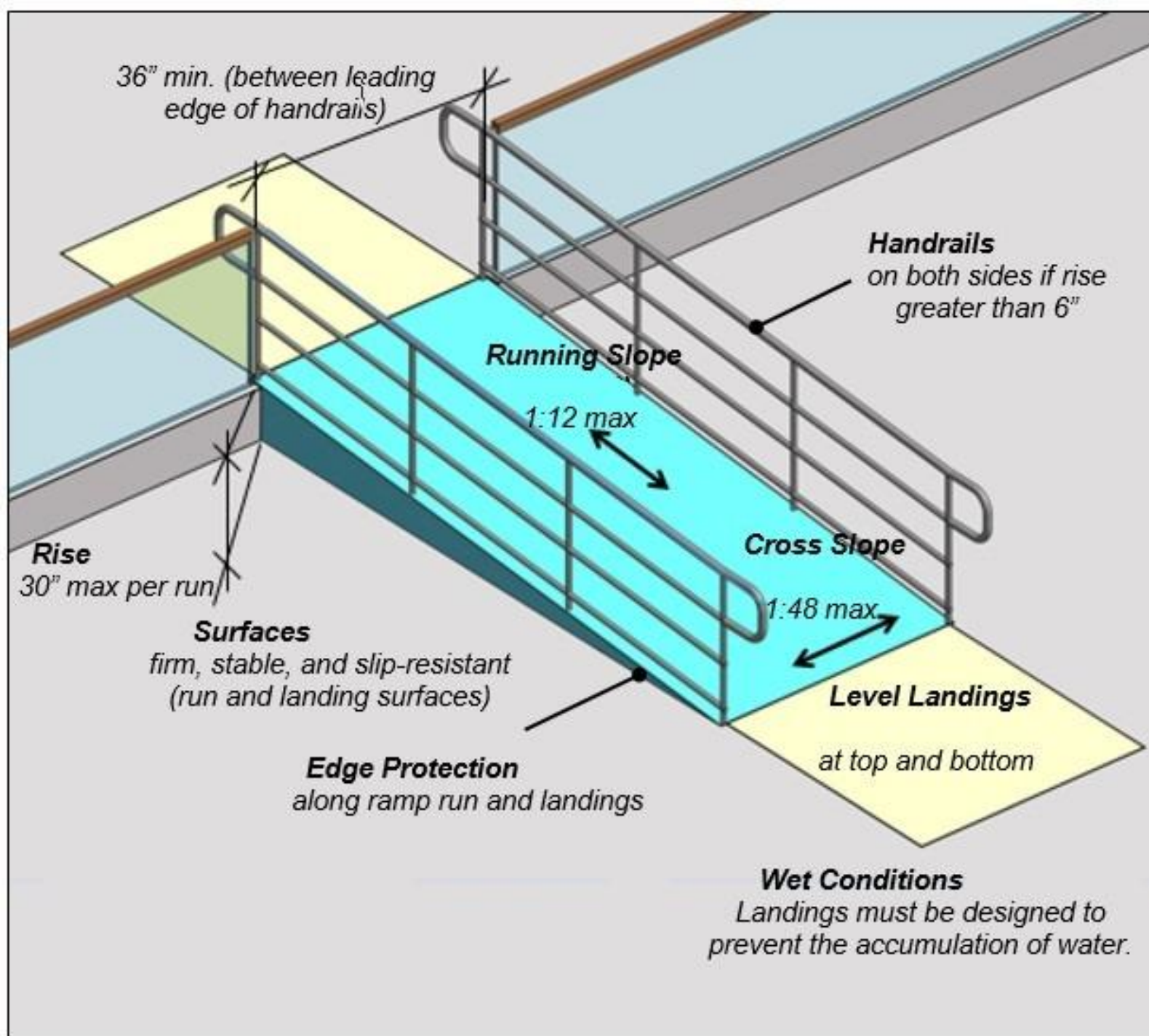

# Accessible Entrances - Scoping

- Part of the accessible route
- Ensure people with disabilities have an accessible way in
- At least 60% of all public entrances must be accessible.
- If direct access to a facility entrance is from a parking structure, each direct access entrance must be accessible.
- If direct access to a facility entrance is from a pedestrian tunnel or elevated walkway, at least one direct entrance to the facility must be accessible.

# Accessible Entrances – Design I

- Revolving doors, revolving gates, and turnstiles not allowed.
- At least one side of double doors must be accessible.
- Door openings must have a clear width of at least 32 inches.
- No protrusions below 34 inches from ground. Protrusions between 34-80 inches above the ground are limited to 4 inches.
- Thresholds at doorways can be no more than ½ inch high. Floor or ground surface requirements apply.



# Accessible Entrances – Design II

- Maneuvering clearances are required and vary.

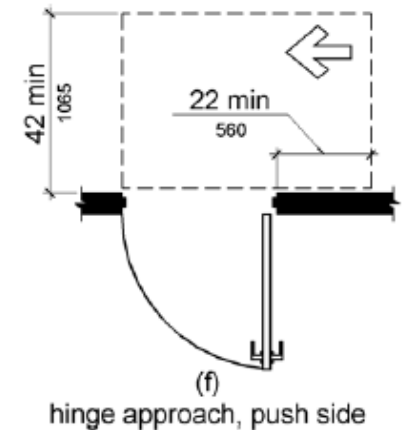
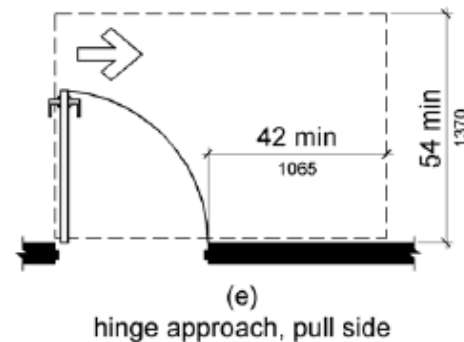
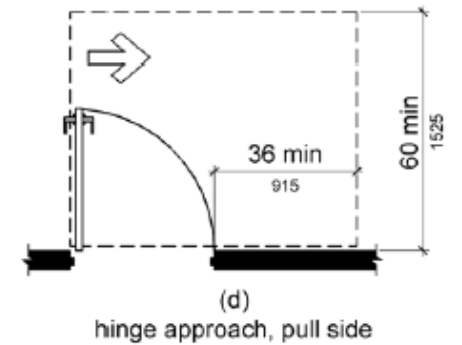
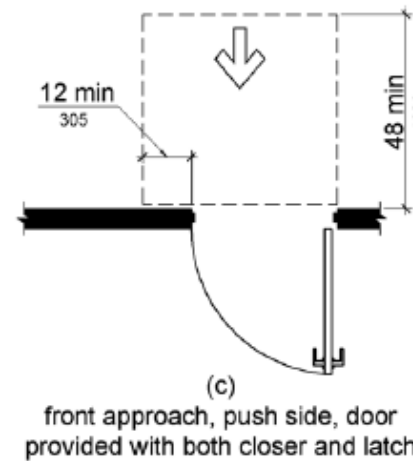
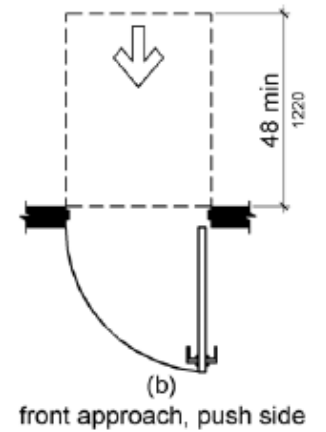
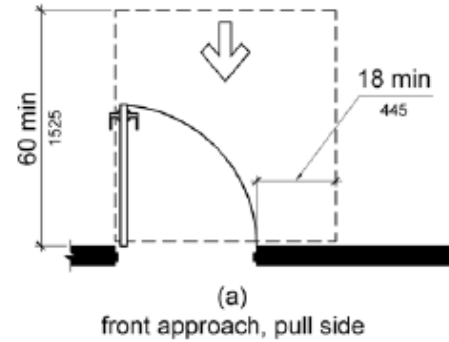



## Accessible Entrances – Design III

- Operable parts of doors must not require tight grasping, pinching or twisting of the wrist.
- Operable parts of doors must be 34-45 inches above the ground.
- Doors must close at a speed of no less than 5 seconds.

# Drive-Thru Medical Testing Sites

- Allow for intermittent medical services
- May be in a parking lot of hospital, retail store or fairground
- Typically consist of pop-up tents and traffic cones
- Useful in viral outbreaks to help minimize exposure to others
- Operations must comply with the Americans with Disabilities Act



# Wheelchair Access at Drive-Thru Testing Sites I

- Minimum clearance for wheelchair-accessible vans is 8 feet, 2 inches high

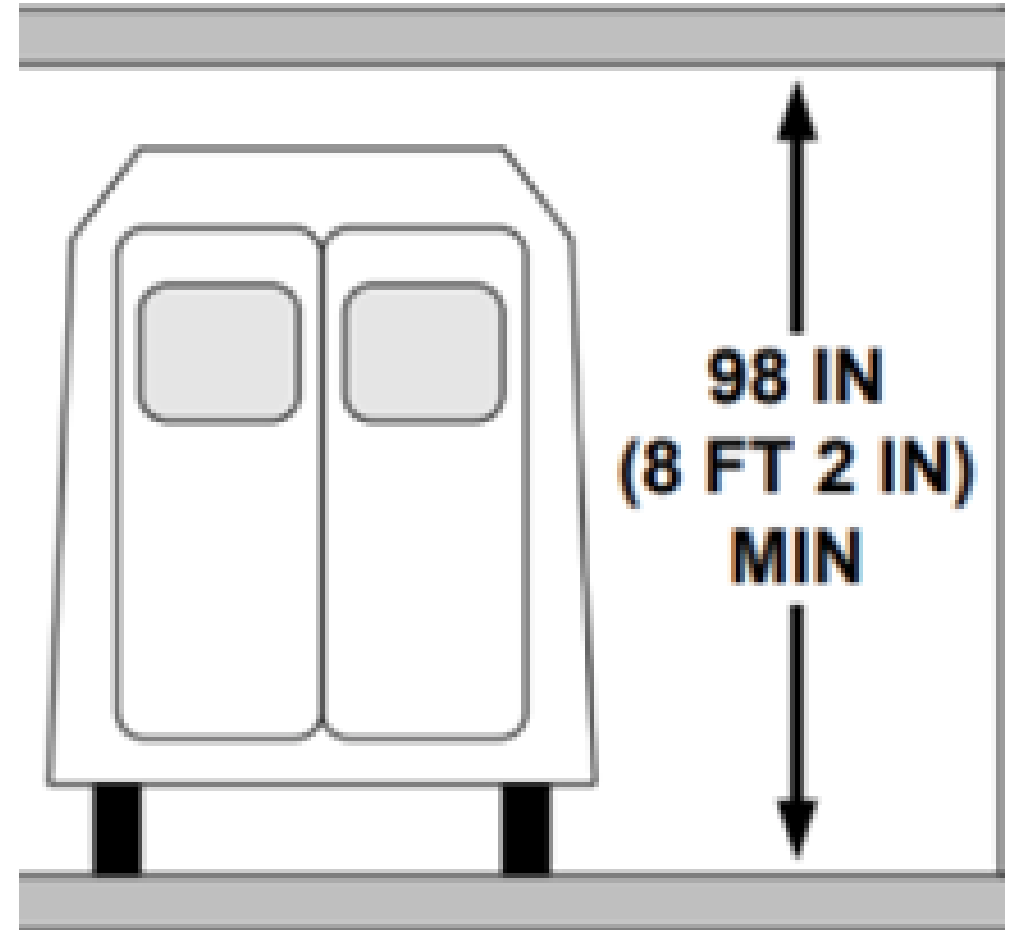

# Wheelchair Access at Drive-Thru Testing Sites II

- Wheelchair users need access aisle alongside vehicle if exiting the vehicle is required

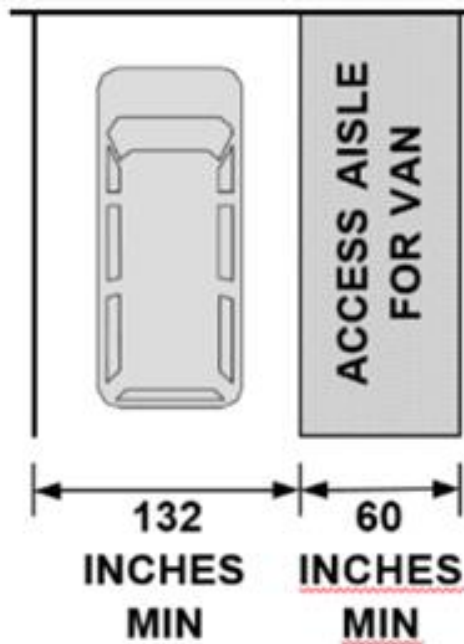

OR

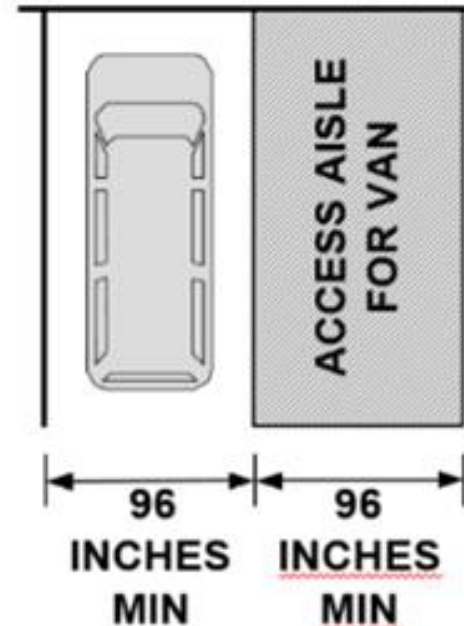

# Walk-Up Services at Drive-Thru Sites

- Walk-up services may be needed for those unable to arrive by vehicle
- Ensure accessible route connecting all elements of testing
  - Check-in
  - Testing area
  - Paperwork/instruction area
  - Check-out

## Accessible Routes

Interior accessible routes must comply with the following:

- Clear width of 36 inches
- Passing space of 60 inches every 200 feet
- No change in level of more than  $\frac{1}{4}$  inch, or  $\frac{1}{2}$  inch if beveled
- Running (forward) slope no greater than 5 percent (1:20)
- Cross slope (side-to-side) no greater than 2 percent (1:48)
- Firm, stable & slip resistant

# Walking Surfaces in Accessible Routes

The clear width may be reduced to 32” minimum for a length of 24” maximum, provided that reduced width segments are separated by segments that are 48” long minimum and 36” wide minimum

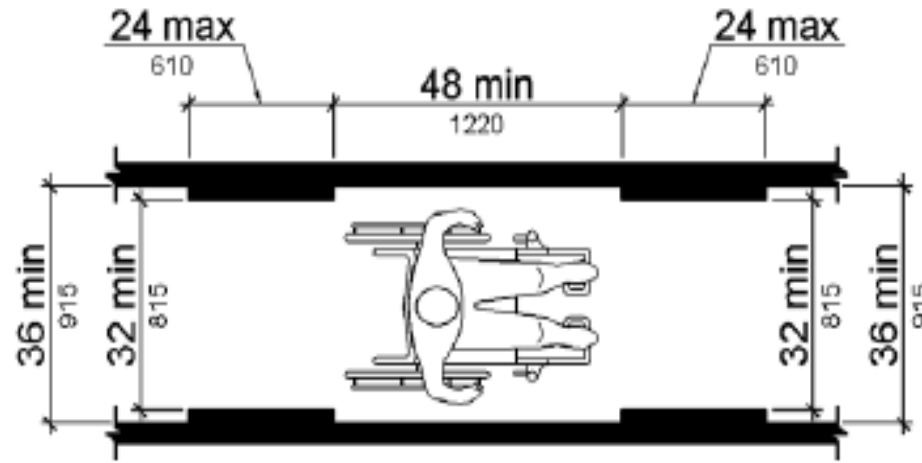



# Accessible Route Multi-Story Exception

Accessible route between floors  
("elevator exemption")

Private sector facilities only that are:  
Less than 3 stories (above or below grade)  
OR less than 3,000 square feet per story



# Elevator Exemption

Exemption not allowed for:

- Shopping centers/ malls with 5 or more sales or retail establishments
- **Professional offices of health care providers**
- Terminal, depots, or stations used for public transportation
- Government facilities where
  - 2 stories only **AND**
  - where 1 story has no public space **AND**
  - maximum occupancy of 5



## Employee Work Areas & Exempt Areas

- Mechanical spaces are generally exempt from accessibility requirements
- Employee work areas must comply with
  - Accessible route requirements
  - Egress (exiting) requirements
  - Visible alarms (when audible alarms exist)
- Employee work areas need not comply with accessible route requirements if they are <1,000 square feet

# Example: Medical Care Suite

## Employee Work Areas & Exempt Spaces

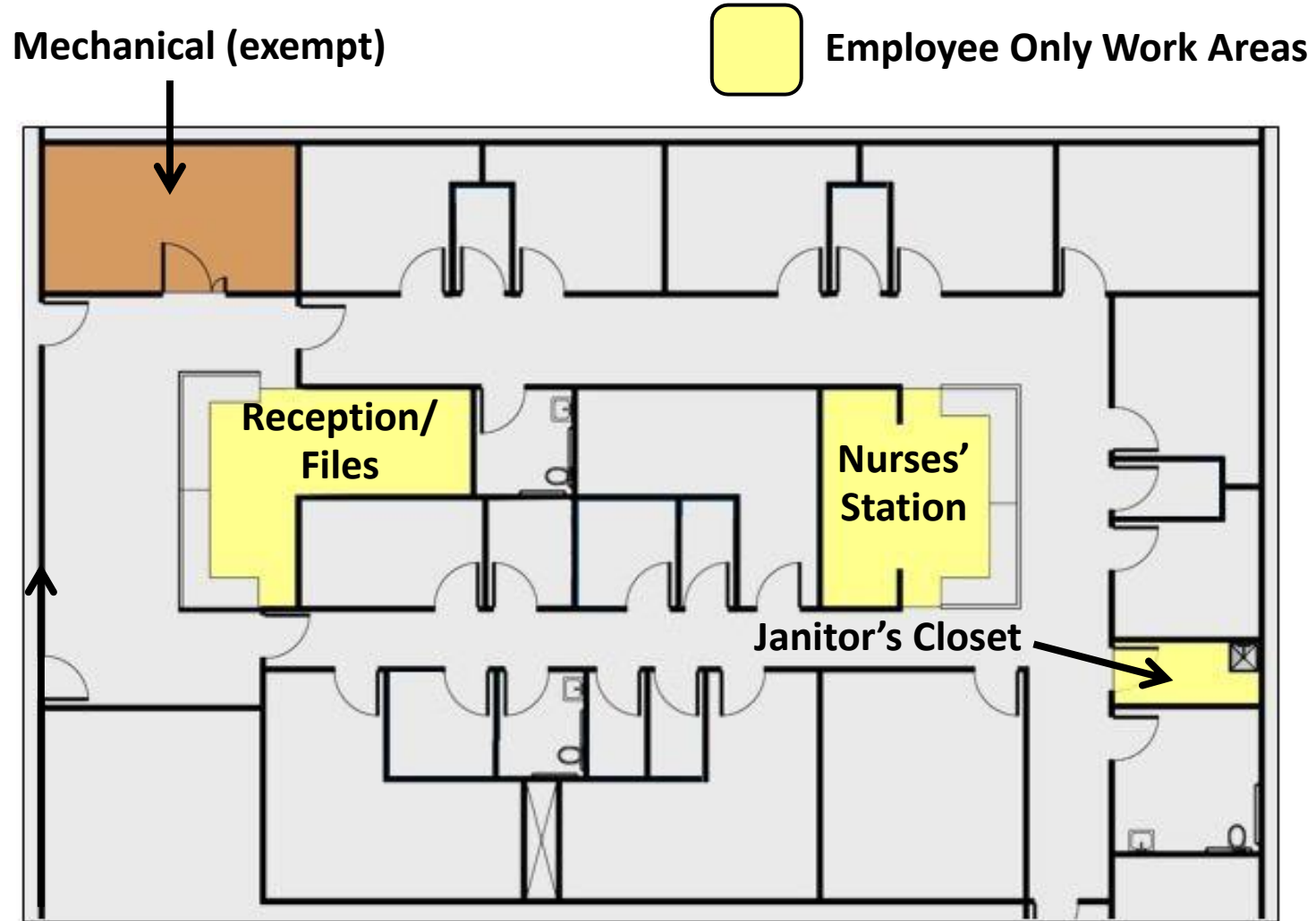

## Doors

Doors must have:

- 32 inches clear width
  - 36 inch clear width if > 24 inches deep
  - No projections into clear width below 34 inches
- Lever handle hardware placed between 34 & 48 inches
- Door closers cannot project more than 4 inches if they are below 80 inches

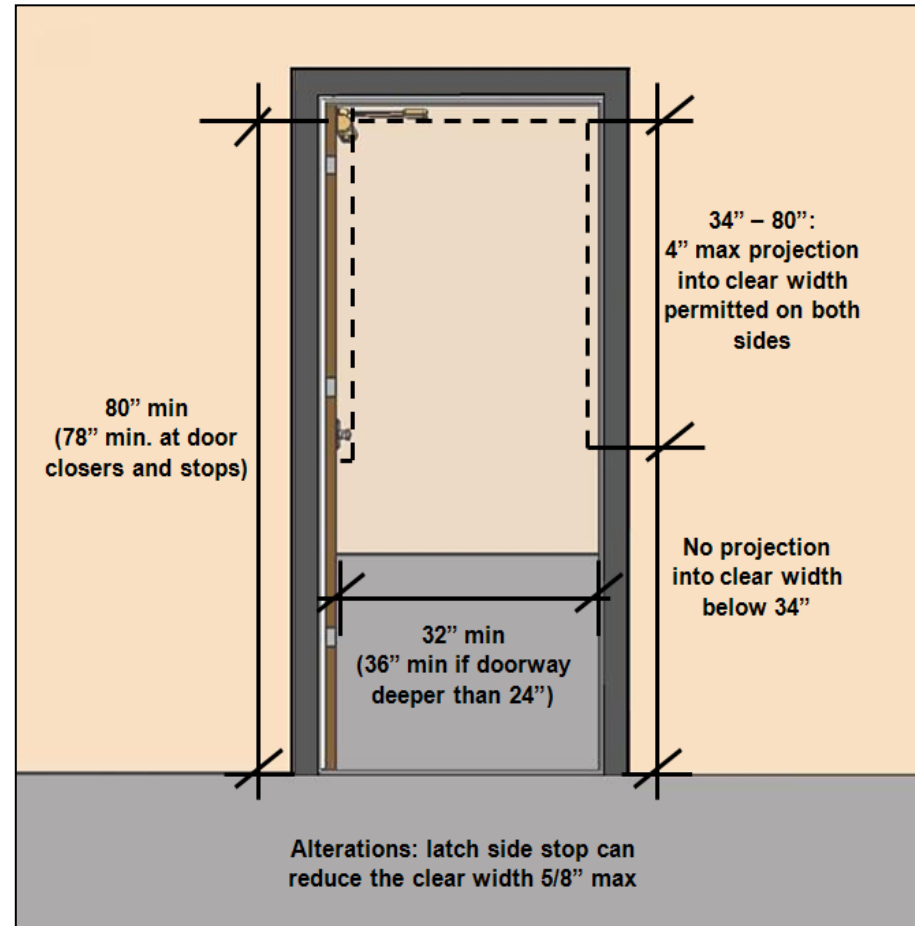

# Maneuvering Clearances

Minimum space for positioning/ maneuvering at doors

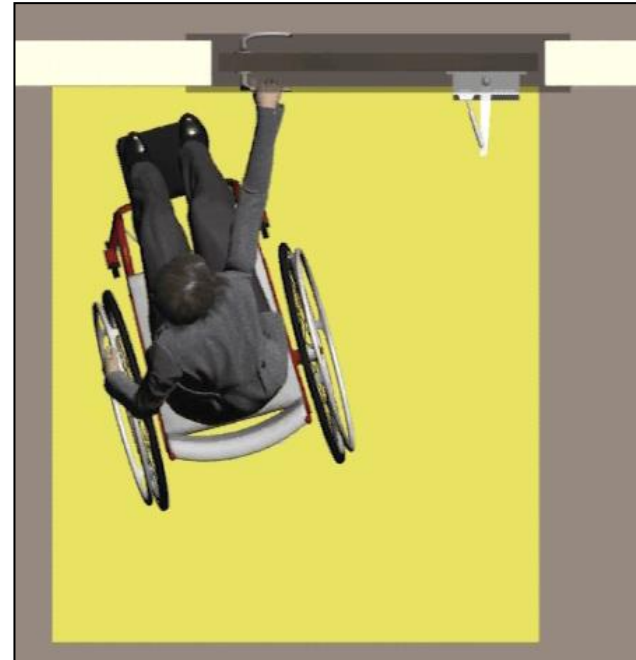

# Maneuvering Clearances - Overlap

Required at each accessible door based on  
approach & swing

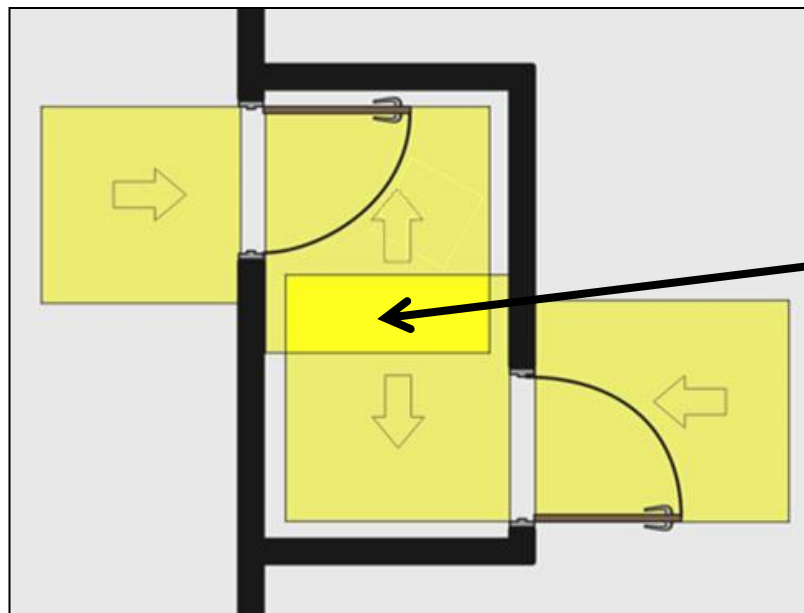

Door  
maneuvering  
clearances can  
overlap

## Maneuvering Clearances - Offset

Maneuvering clearance measured from the wall - Cannot be offset more than 8" from the face of the door.

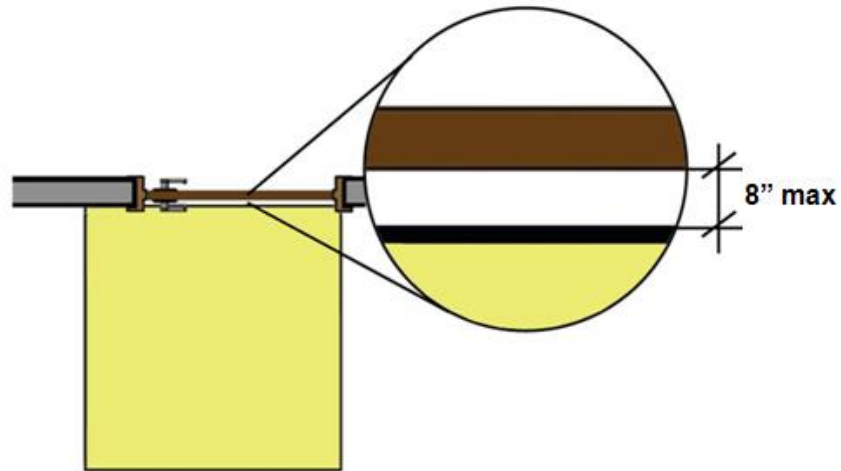



## Maneuvering Clearances – Recessed Door



Recess: 8" max.

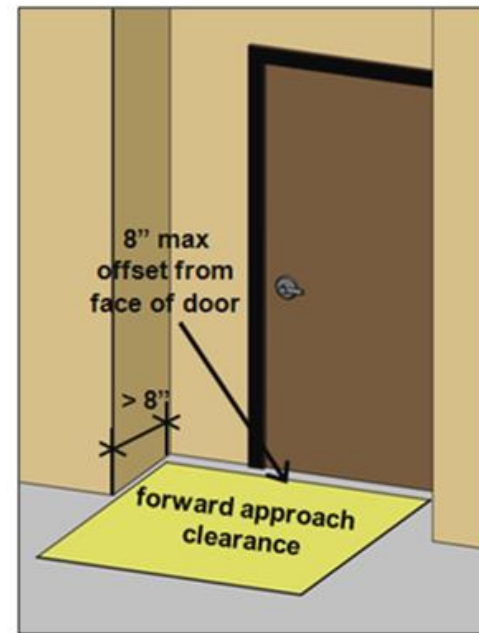

Recess: greater than 8"

# Maneuvering Clearances at Doors/Gates Table

Type of Use		Minimum Maneuvering Clearance	
Approach Direction	Door or Gate Side	Perpendicular to Doorway	Parallel to Doorway (beyond latch side unless noted)
From front	Pull	60 inches (1524 mm)	18 inches (455 mm)
From front	Push	48 inches (1219 mm)	0 inches (0 mm) <sup>1</sup>
From hinge side	Pull	60 inches (1525 mm)	36 inches (915 mm)
From hinge side	Pull	54 inches (1370 mm)	42 inches (1065 mm)
From hinge side	Push	42 inches (1065 mm) <sup>2</sup>	22 inches (560 mm) <sup>3</sup>
From latch side	Pull	48 inches (1220 mm) <sup>4</sup>	24 inches (610 mm)
From latch side	Push	42 inches (1065 mm) <sup>4</sup>	24 inches (610 mm)

1. Add 12 inches (305 mm) if closer and latch are provided.
2. Add 6 inches (150 mm) if closer and latch are provided.
3. Beyond hinge side.
4. Add 6 inches (150 mm) if closer is provided.

## Clustered Areas

- Accessible dressing rooms & toilet rooms can be grouped or “clustered” if:
  - 5 percent of each type of dressing room, or at least 1, comply with accessibility requirements in ADA 803
  - 50 percent of the clustered toilet rooms, at least 1, comply with the accessibility requirements for toilet rooms in ADA 603
  - The rooms are in the same general area
  - They serve the same group of people (i.e., the public vs employees)

# Example: Medical Care Suite

## Public & Common Use Areas: Full Access

 Dressing Rooms: access to at least 5% of each type

Exams Rooms & Doctors' Offices: 100% scoping (public access)

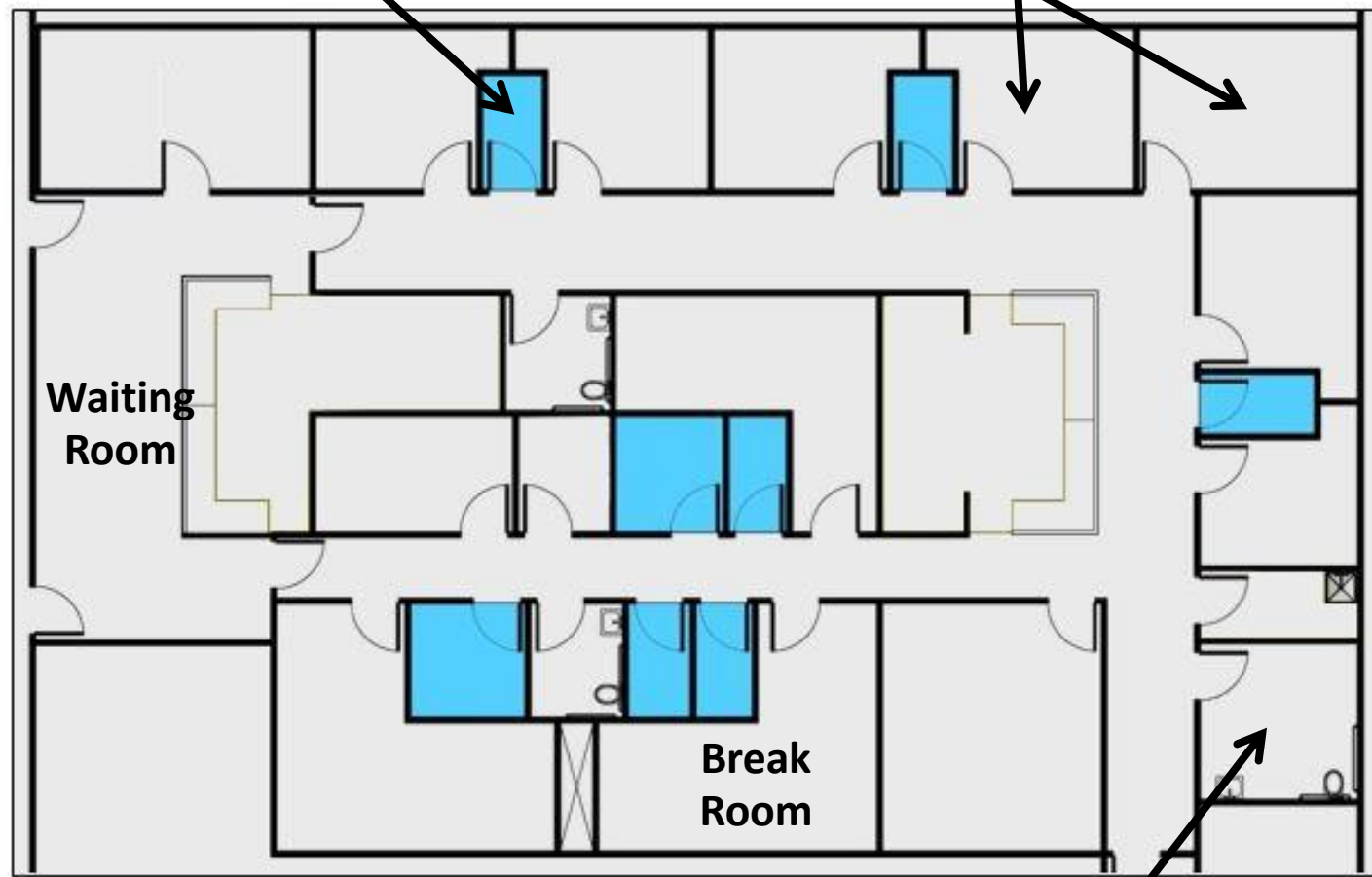

Toilet rooms – access to all  
(50%: clustered single user of same type)

# Clustered Toilet Rooms

**Access to at least 50% of single user toilet rooms clustered at 1 location & serving same users**



# Toilet Rooms (§603)

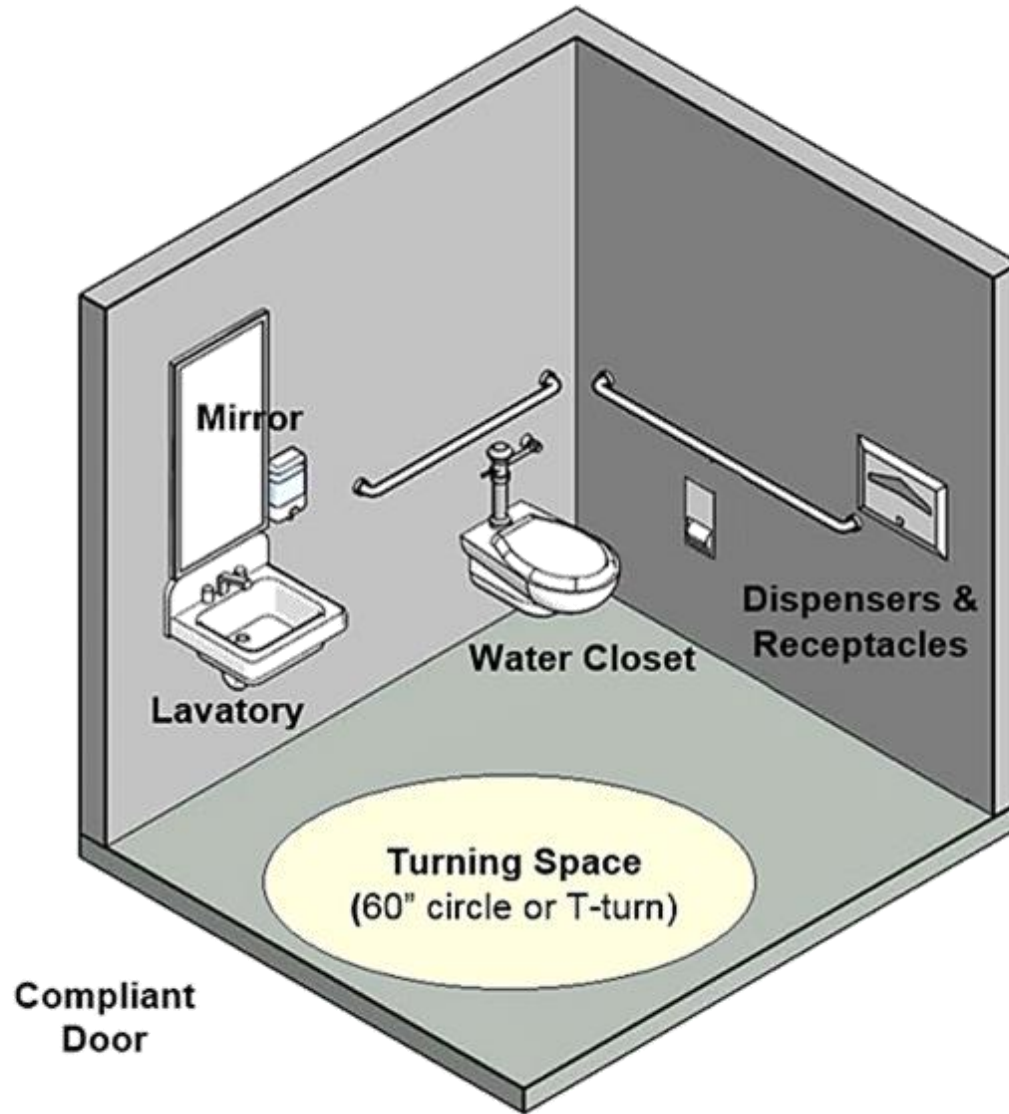

**Coat Hooks  
& Shelves**



**Urinal**  
(if more than  
one provided)

# Toilet Rooms – Exterior Door Maneuvering Clearance

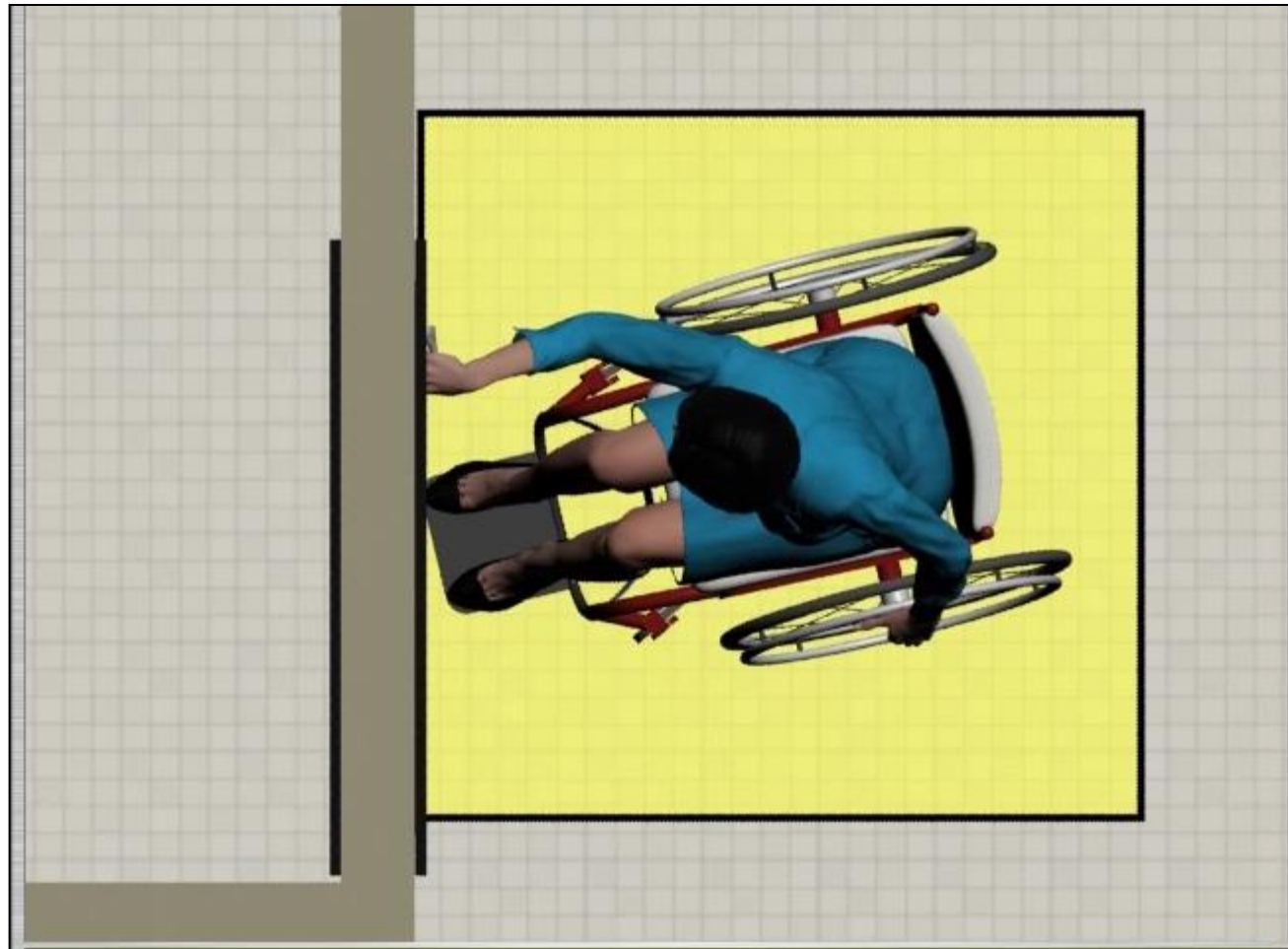

# Toilet Rooms - Clear Floor Space at Toilet for Approach & Transfer

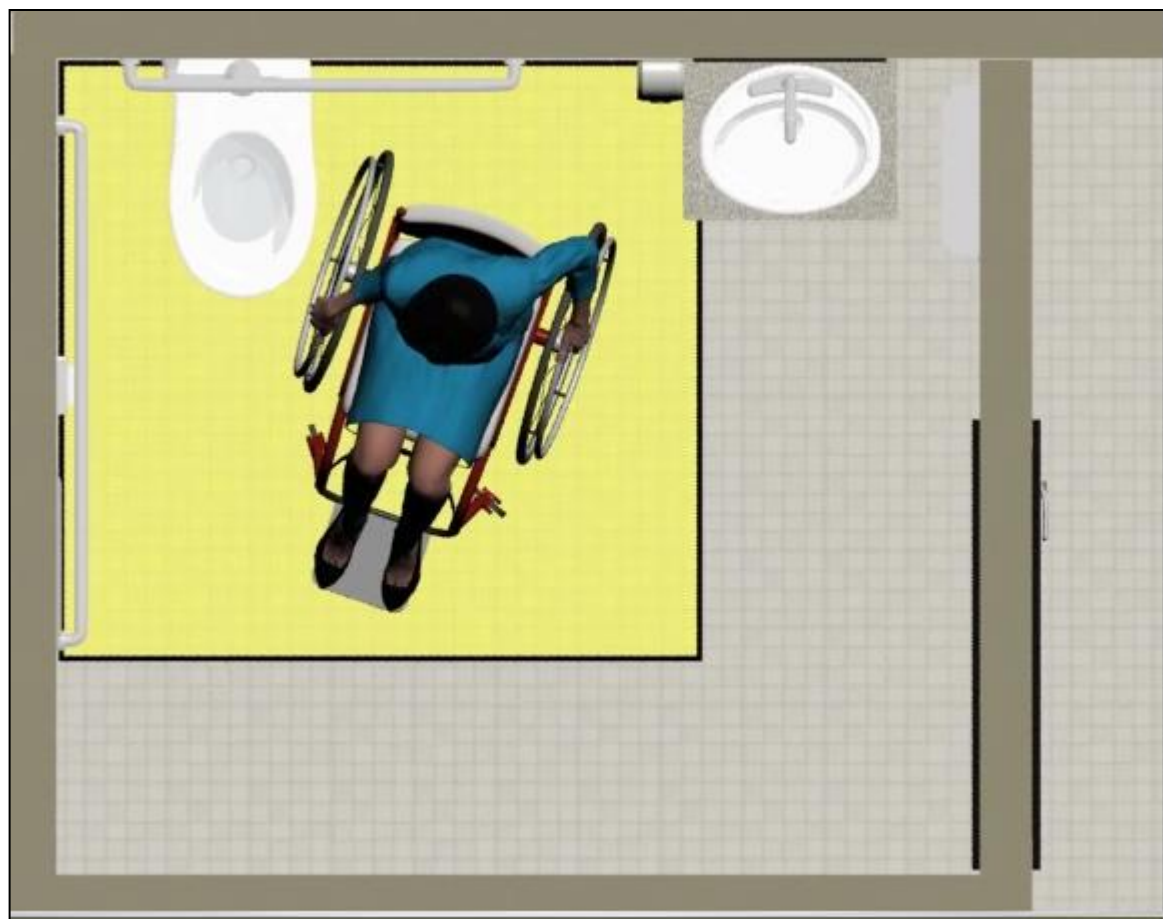



## Toilet Rooms – Turning Space

**60" diameter circle or  
"T" shaped space**

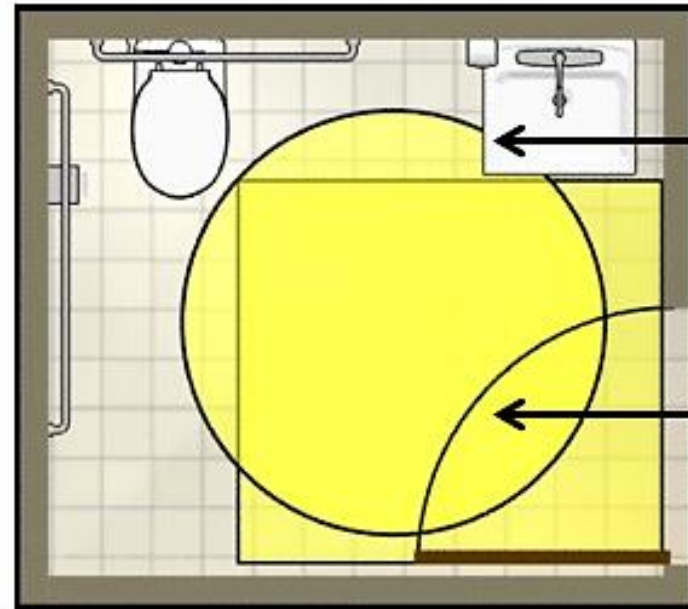

**Elements with knee/toe  
clearance can overlap  
turning space**

**Door can always swing  
into turning space**

# Toilet Rooms - Clear Floor Space at Fixtures & Elements

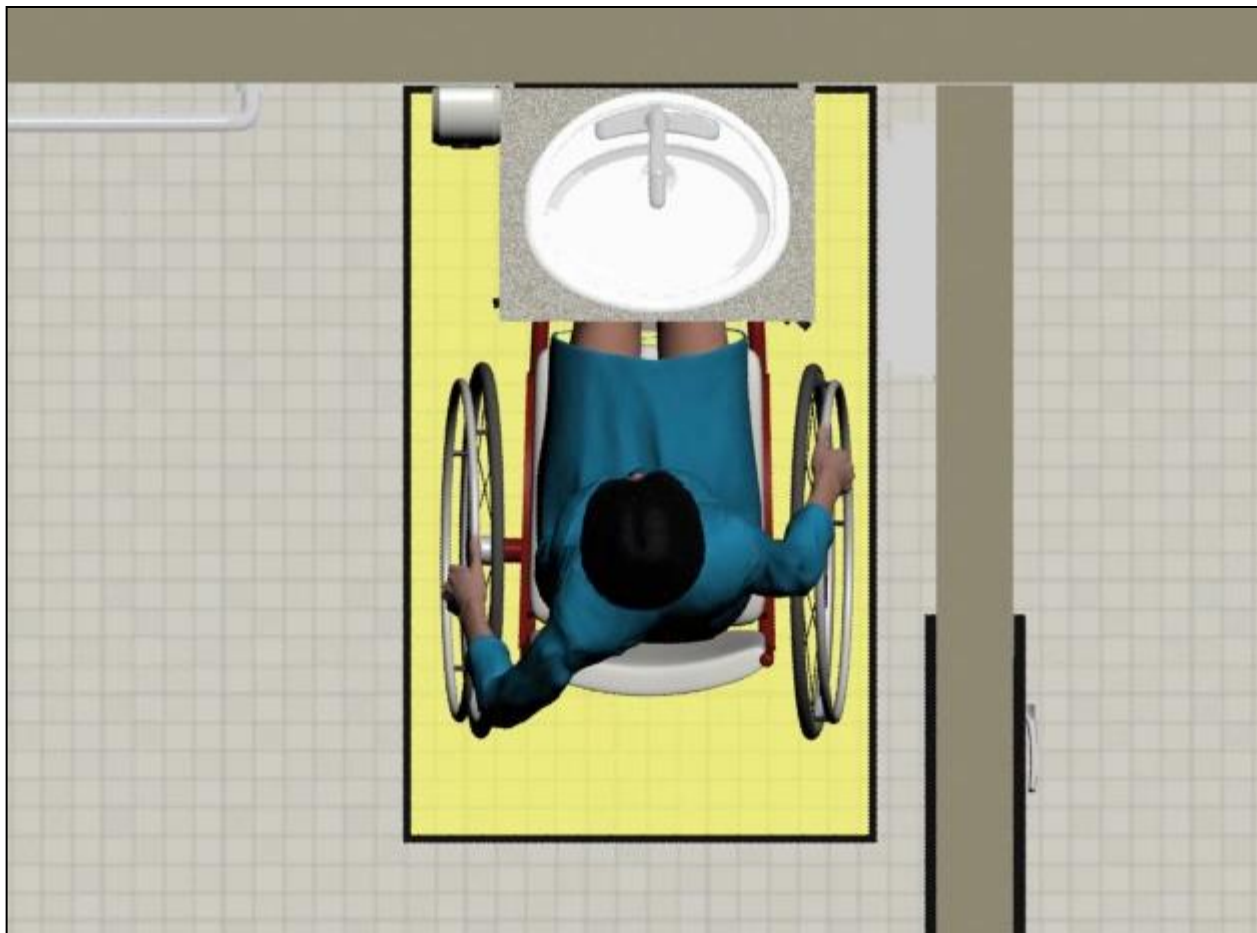

# Toilet Rooms - Interior Door Maneuvering Clearance

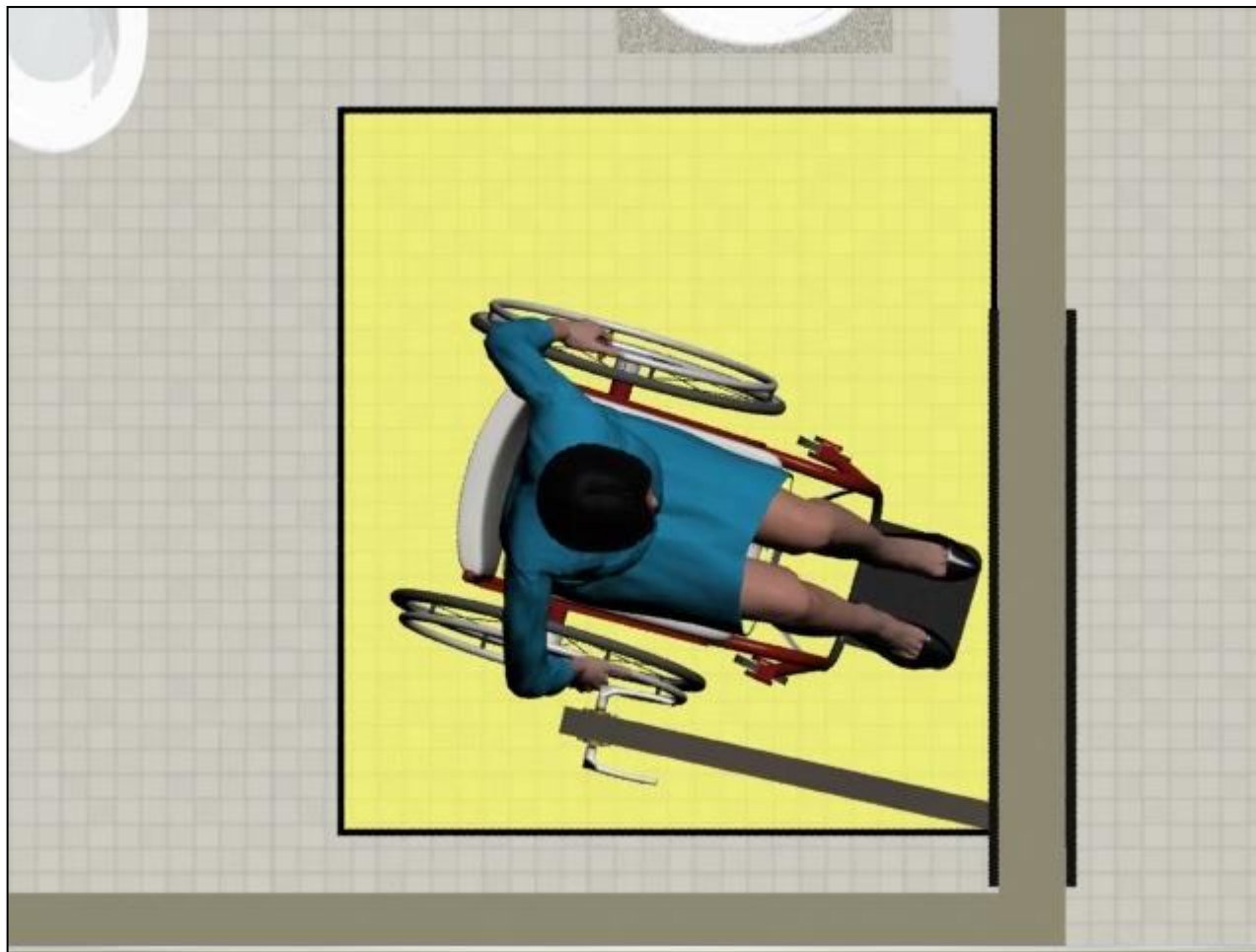

# Toilet Rooms – No Overlap of Lavatory & Toilet Clearances

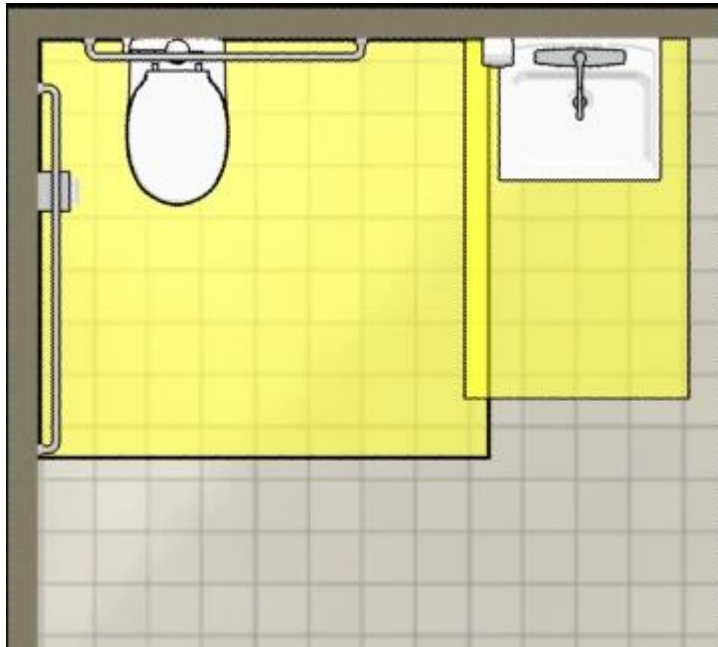

Shorter (24" min.) rear GB  
allowed when fixture recessed

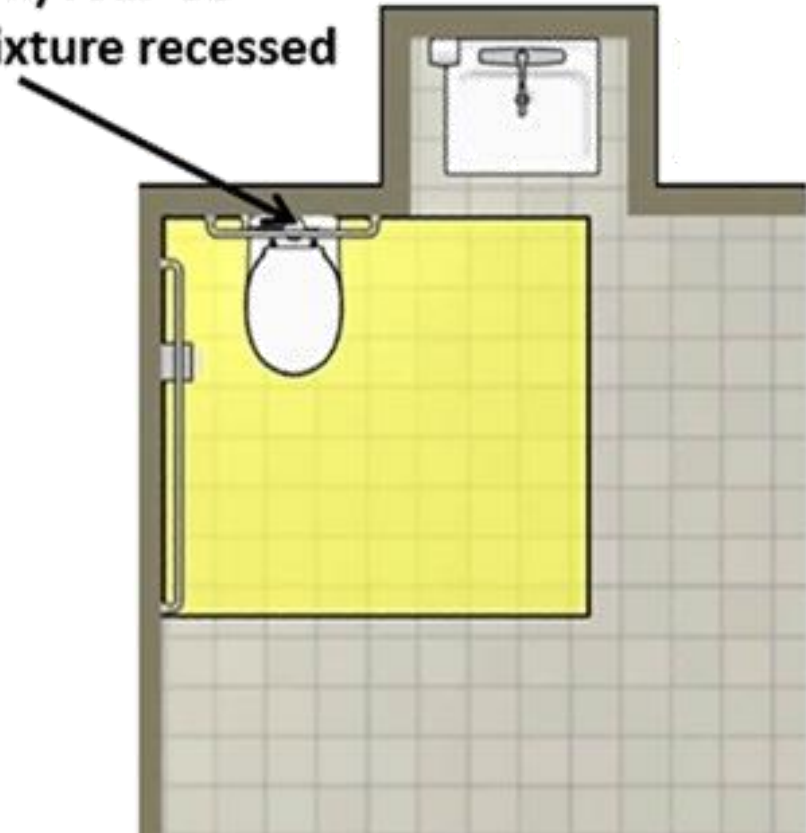

# Toilet Rooms – Interior Door Maneuvering Clearance

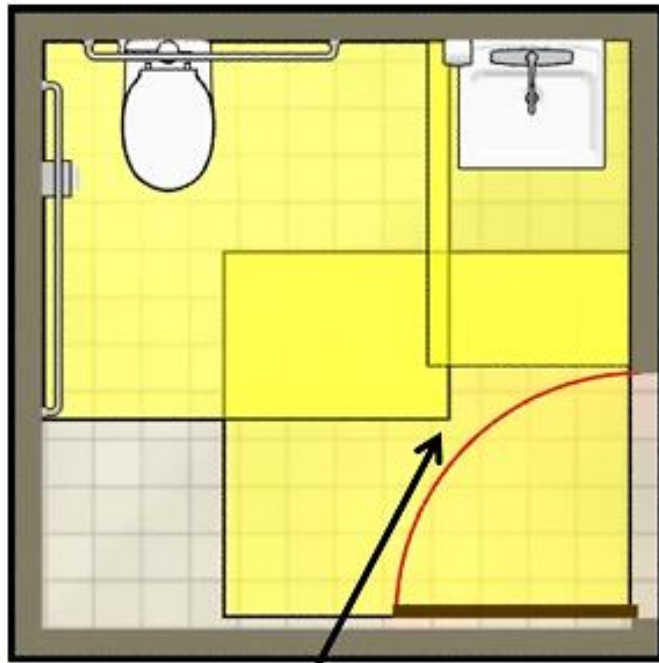

**Keep swing outside fixture clearances or ...**

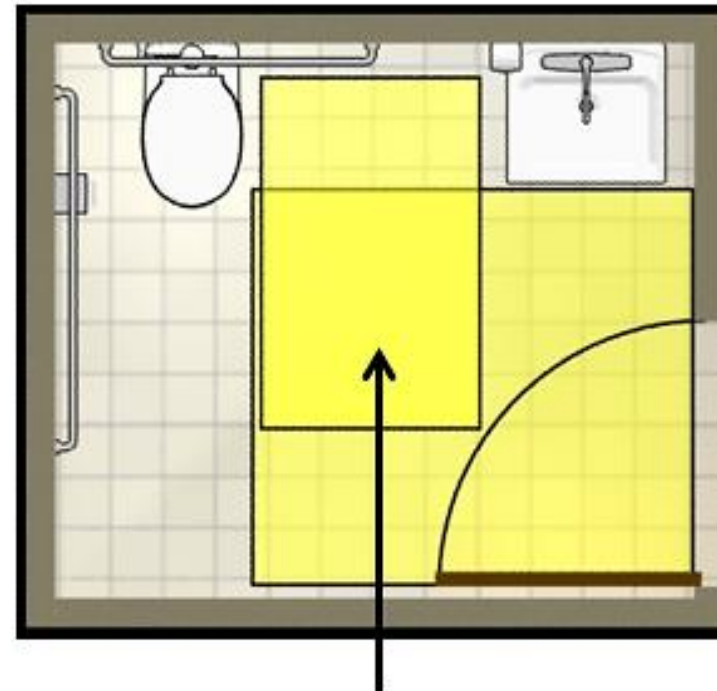

**... provide unobstructed clear floor space (30" x 48" min.) outside swing (location not specified)**

## Toilet Rooms – Out-swinging Doors

**Out-swinging doors allow smaller room size  
(require less interior maneuvering clearance)**

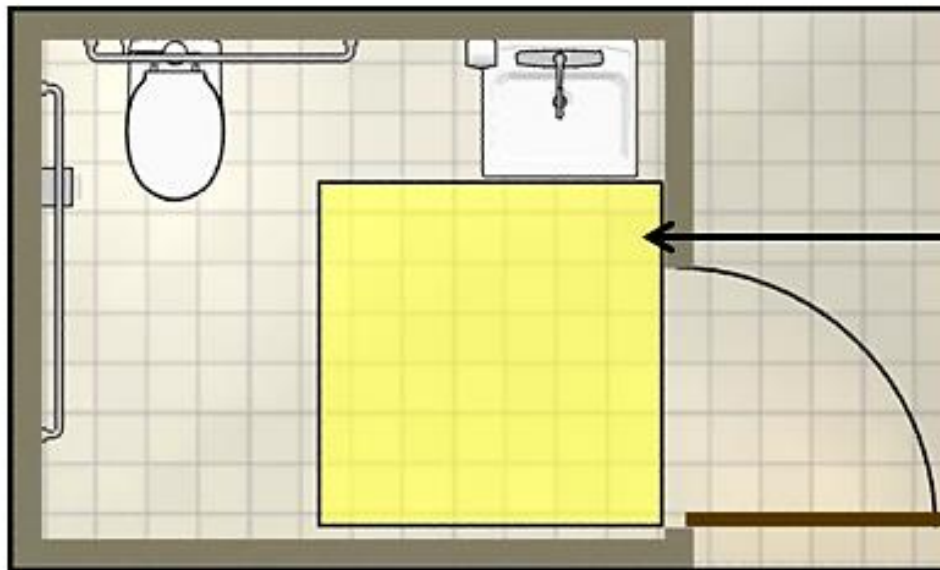

12" min. latch-side clearance  
required on push side  
(forward approach) if door  
has both a closer & latch

## Accessible Check-In Areas

The check-in counter in a medical office or hospital must meet the following:

- A portion of the counter surface 36 inches long minimum and 36 inches high maximum above the finish floor must be provided.
- A clear floor or ground space complying with ADA 305 must be positioned for a **parallel** approach adjacent to the 36 inch minimum length of counter; or
- must be positioned for a **forward** approach to the counter (with knee & toe clearance)

## Accessible Examination Rooms

- Accessible examination rooms must have:
  - an accessible route to and through the room;
  - an entry door with adequate clear width, maneuvering clearance, and accessible hardware;
  - appropriate models and placement of accessible examination equipment; and
  - adequate clear floor space inside the room for side transfers and use of lift equipment



# Medical Diagnostic Equipment (MDE) Standards

**Issued by the U.S. Access Board, the MDE Standards:**

- **are found in the Rehabilitation Act section 510**
- **provide technical criteria**
- **are voluntary unless adopted by an enforcing authority (e.g., DOJ under the ADA, HHS under the Rehabilitation Act)**
- **can be used by FDA to verify labelling claims**

# Equipment Covered

- **examination tables**
- **examination chairs (including those used for dental or optical exams)**
- **weight scales**
- **x-ray machines**
- **mammography equipment**
- **other MDE**



# Equipment Not Covered

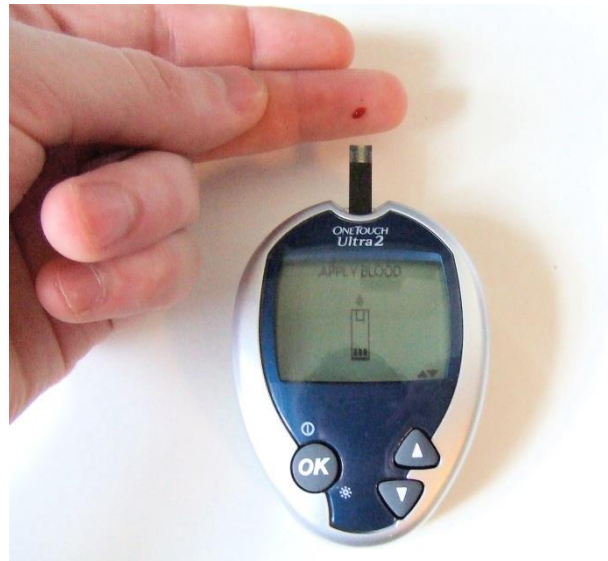

**Standards do not apply to personal devices or  
positioning aids**

## **MDE Technical Requirements**

**Apply based on patient position for use:**

- **Supine, Prone, or Side Lying (M301)**
- **Seated (M302)**
- **In Wheelchair (M303)**
- **Standing (M304)**

**Also address: supports (M305), communication (M306) & operable Parts (M307)**

# Supine, Prone or Side-Lying MDE Transfer Surface

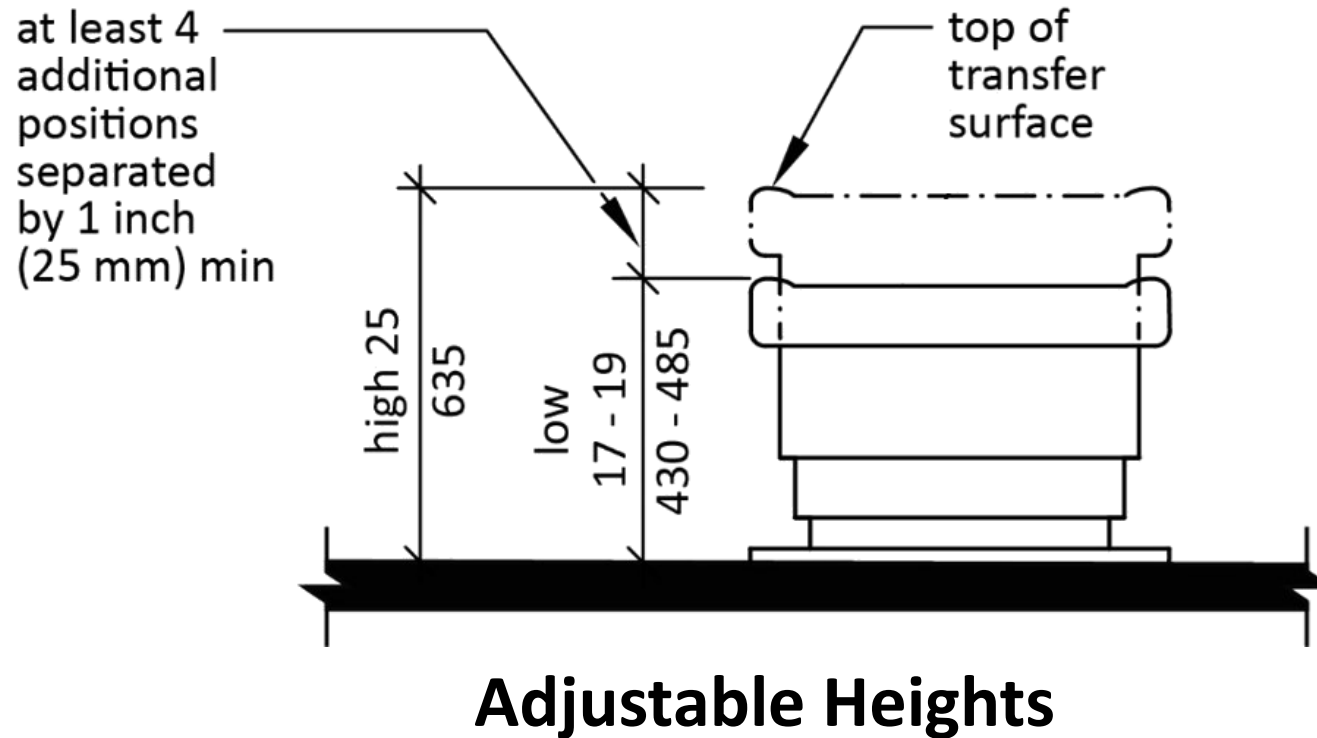

**Low: 17 – 19”**

**High: 25”**

**Additional Heights: at least 4 between low and high separated by at least 1”**

# Seated in a Wheelchair Pass Through Entry/ Exit MDE

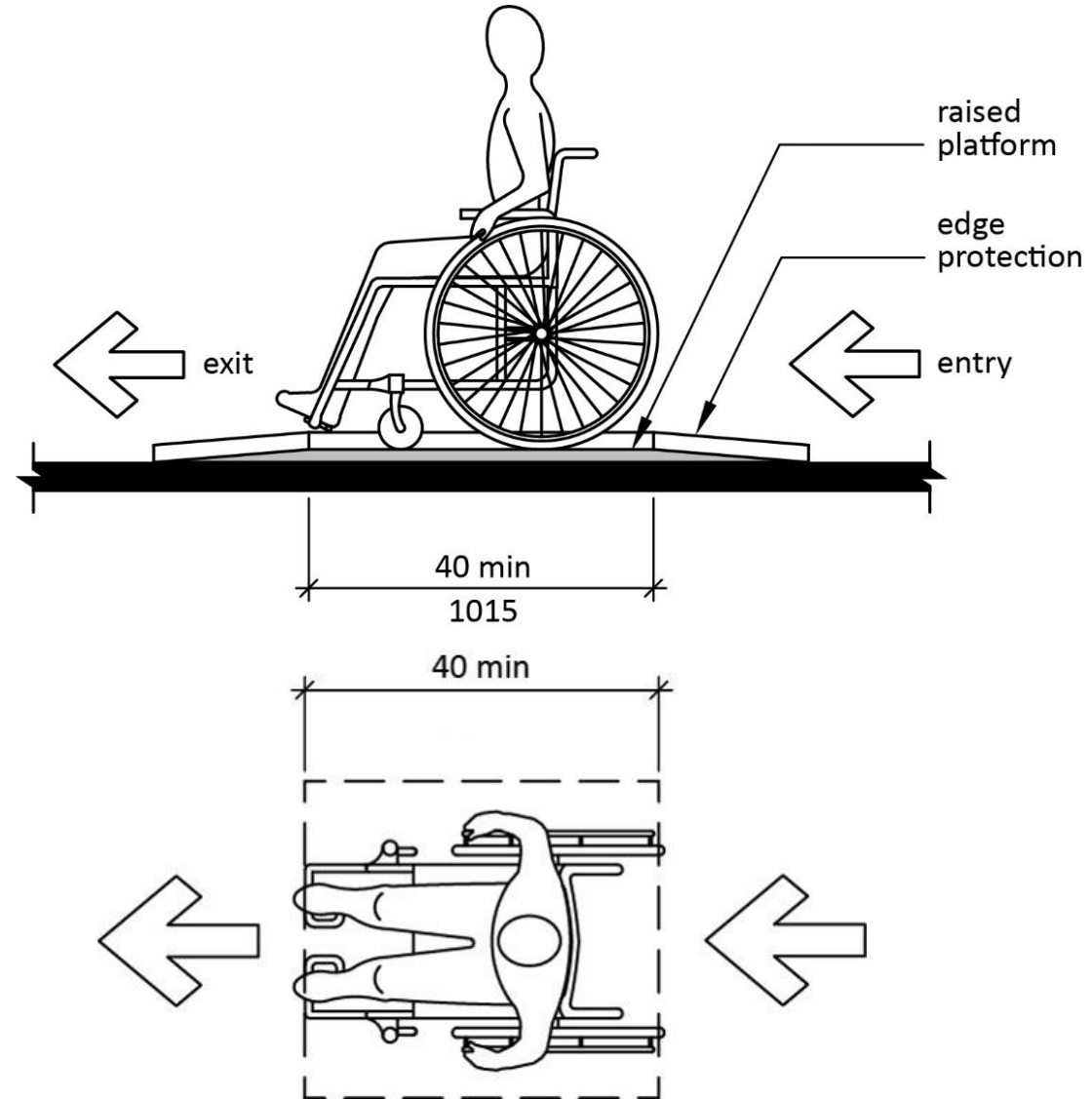

# Standing MDE Requirements

- **Slip-resistant surface**
- **Vertical support gripping surface:**
  - **18" long min**
  - **34" - 37" height (lower end of gripping surface)**
- **Horizontal support gripping surface:**
  - **4" long min**
  - **34" - 38" height (top of gripping surface)**

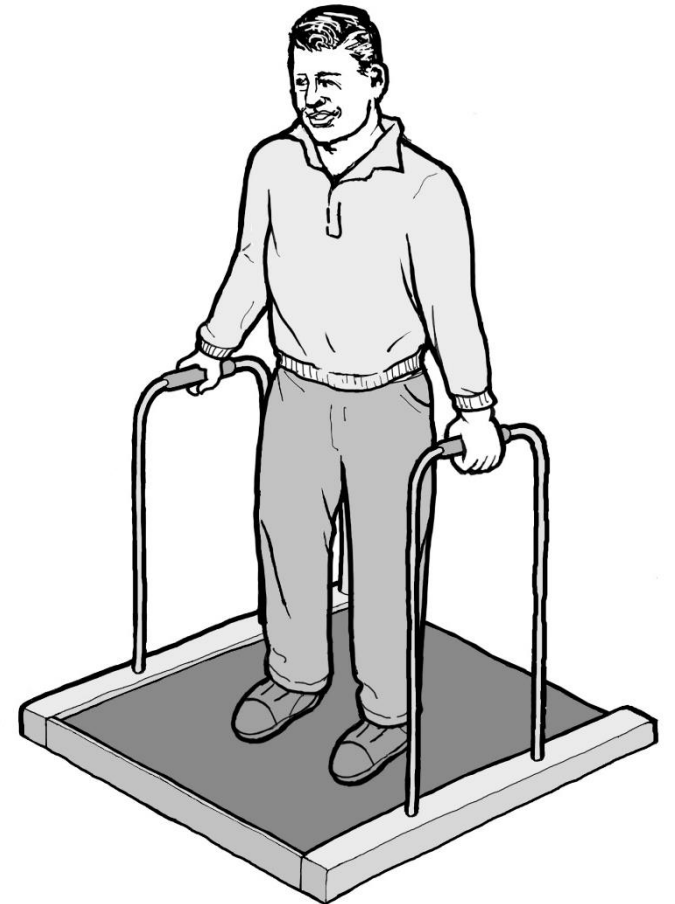

## Tax Incentives

- Health care providers can receive tax incentives for physical accessibility changes, transportation accessibility modifications, and communication accessibility expenses
- View the ADA National Network Quick Tips - <https://adata.org/factsheet/quicktips-tax>
- Consult your tax professional



## Resources

- 2010 ADA Standards - <https://www.ada.gov/regs2010/2010ADAStandards/2010ADASTandards.htm>
- Medical Diagnostic Equipment - <https://www.access-board.gov/guidelines-and-standards/health-care/about-this-rulemaking>
- ADA National Network – [www.adata.org](http://www.adata.org)
- Rocky Mountain ADA Center – <https://www.rockymountainada.org>
- Pacific ADA Center - <https://www.adapacific.org>